



TITAN®

OPERATION MANUAL

HELIX™

LOW PRESSURE SPRAY
FOAM PROPORTIONER

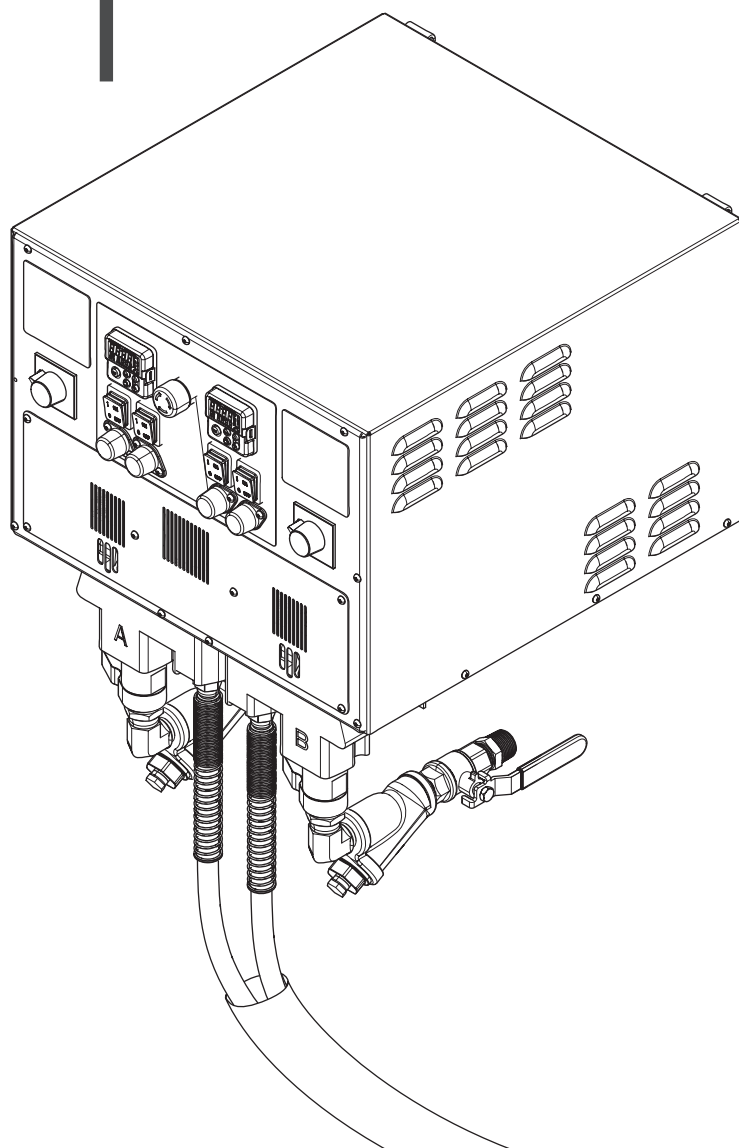

Models: **0138040** **(200' hose)**
 0138065 **(100' hose)**

Warning!

Attention: Danger of injury by injection!
Airless units develop extremely high spraying pressures.



1

Never put your fingers, hands or any other parts of the body into the spray jet!

Never point the spray gun at yourself, other persons or animals. Never use the spray gun without safety guard.

Do not treat a spraying injury as a harmless cut. In case of injury to the skin through coating materials or solvents, consult a doctor immediately for quick and expert treatment. Inform the doctor about the coating material or solvent used.

2

The operating instructions state that the following points must always be observed before starting up:

1. Faulty units must not be used.
2. Ensure that the unit is properly earthed.
3. Check all connections for leaks.

3

The instructions regarding regular cleaning and maintenance of the unit must be strictly observed.

Before any work is done on the unit or for every break in work the following rules must be observed:

1. Release the pressure from spray gun and hose.
2. Switch off unit.
3. Unplug the power cord from the unit.

Be safety conscious!

1	SAFETY REGULATIONS	4	6	OPERATION	20
1.1	Explanation of symbols used	4	6.1	Startup	20
1.2	Isocyanate (ISO) Conditions	6	6.2	Set heated hose temperature	20
1.3	Electric safety	7	6.3	Spraying	21
2	GENERAL DESCRIPTION	8	6.4	Pressure relief procedure	21
2.1	System configurations	8	7	SHUTTING DOWN	22
2.2	Mounting diagram	9	7.1	Parking	22
2.3	Electrical / generator requirements	9	7.2	Flushing	23
3	SYSTEM DESCRIPTION	10	8	TROUBLESHOOTING	24
3.1	System diagram - drum LP unit	10	8.1	Component pumps	24
3.2	Component description - drum LP unit	11	8.2	Heated hose controller errors	25-27
4	CONTROL PANEL	12	9	SERVICING	28
4.1	Heated hose temperature control	13	9.1	Replacing the motor assembly	28
4.2	Component pump pressure control	13	9.2	Replacing the gears	29
4.3	Control Displays	14	9.3	Inlet and outlet valves	30
4.4	Control Displays Error Messages	16	9.4	Packings	31
5	SETUP	17	9.5	Electrical schematic	32/33
5.1	Locate the system	17	SPARE PARTS LISTS		
5.2	Connect the material supply hoses	17	34		
5.3	Connect the air supply	18	Spare parts list for main assembly I		
5.4	Connect the heated hoses	18	34/35		
5.5	Connect the electrical cord	18	Spare parts list for main assembly II		
5.6	Ground the system	19	36/37		
5.7	Lubricate the component pumps	19	Spare parts list for component pump assembly		
			38/39		
			Spare parts list for display assembly		
			40/41		
			Spare parts list for the bracket kit		
			42/43		
			Spare parts list for fluid section		
			44/45		
			WARRANTY		
			46		

1 SAFETY REGULATIONS

1.1 EXPLANATION OF SYMBOLS USED

This manual contains information that must be read and understood before using the equipment. When you come to an area that has one of the following symbols, pay particular attention and make certain to heed the safeguard.



→ This symbol indicates a potential hazard that may cause serious injury or loss of life. Important safety information will follow.



Attention

→ This symbol indicates a potential hazard to you or to the equipment. Important information that tells how to prevent damage to the equipment or how to avoid causes of minor injuries will follow.



→ Danger of skin injection



→ Danger of fire from solvent and spray fumes



→ Danger of explosion from solvent, spray fumes and incompatible materials



→ Danger of injury from inhalation of harmful vapors



→ Danger of injury from burns



→ Danger of injury from electric shock



→ Notes give important information which should be given special attention.



HAZARD: INJECTION INJURY

Attention: Danger of injury by injection! A high pressure stream produced by this equipment can pierce the skin and underlying tissues, leading to serious injury and possible amputation.

Do not treat a spraying injury as a harmless cut. In case of injury to the skin through coating materials or solvents, consult a doctor immediately for quick and expert treatment. Inform the doctor about the coating material or solvent used.

PREVENTION:

- NEVER aim the gun at any part of the body.
- NEVER allow any part of the body to touch the fluid stream. DO NOT allow body to touch a leak in the fluid hose.
- NEVER put your hand in front of the gun. Gloves will not provide protection against an injection injury.
- ALWAYS shut the fluid pump off and release all pressure before servicing or leaving unattended.
- All accessories must be rated at or above the maximum operating pressure range of the sprayer. This includes guns, extensions, and hose.



HAZARD: EXPLOSION OR FIRE

Solvent and material fumes can explode or ignite. Severe injury and/or property damage can occur.



PREVENTION:

- Do not use materials with a flashpoint below 38° C (100° F). Flashpoint is the temperature at which a fluid can produce enough vapors to ignite.
- Do not use a material or solvent containing halogenated hydrocarbons. Such as chlorine, bleach, mildewcide, methylene chloride and trichloroethane. They are not compatible with aluminum. Contact the coating supplier about compatibility of material with aluminum.
- Do not use the unit in work places which are covered by the explosion protection regulations.
- Provide extensive exhaust and fresh air introduction to keep the air within the spray area free from accumulation of flammable vapors.
- Avoid all ignition sources such as static electricity sparks, electrical appliances, flames, pilot lights, hot objects, and sparks from connecting and disconnecting power cords or working light switches.
- Do not smoke in spray area.

- Place sprayer sufficient distance from the spray object in a well ventilated area. Flammable vapors are often heavier than air. Floor area must be extremely well ventilated. The pump contains arcing parts that emit sparks and can ignite vapors.
- The equipment and objects in and around the spray area must be properly grounded to prevent static sparks.
- Use only conductive or earthed high pressure fluid hose.
- Power cord must be connected to a grounded circuit (electric units only).
- Follow material and solvent manufacturer’s warnings and instructions. Be familiar with the coating material’s SDS sheet and technical information to ensure safe use.
- Use lowest possible pressure to flush equipment.
- When cleaning the unit with solvents, the solvent should never be sprayed or pumped back into a container with a small opening (bunghole). An explosive gas/air mixture can arise. The container must be earthed.



HAZARD: HAZARDOUS VAPORS

Solvents and other materials can be harmful if inhaled or come in contact with body. Vapors can cause severe nausea, fainting, or poisoning.

PREVENTION:

- Wear respiratory protection when spraying. Read all instructions supplied with the mask to be sure it will provide the necessary protection.
- All local regulations regarding protection against hazardous vapors must be observed.
- Wear protective eyewear.
- Protective clothing, gloves and possibly skin protection cream are necessary for the protection of the skin. Observe the regulations of the manufacturer concerning coating materials, solvents and cleaning agents in preparation, processing and cleaning units.



HAZARD: BURN HAZARD

Certain components of the equipment are heated and become hot during operation.

PREVENTION:

- To avoid severe burns and injury, do not touch heated fluid or equipment. Wait until the equipment has completely cooled.



HAZARD: THERMAL EXPANSION

Heated fluids, when in confined areas such as spray hoses, can create a rapid rise in pressure due to thermal expansion. Over-pressurization can lead to a rupture and serious injury.

PREVENTION:

- Before each use, check all hoses for cuts, leaks, abrasion or bulging of cover. Check for damage or movement of couplings. Immediately replace the hose if any of these conditions exist. Never repair a spray hose. Replace it with another earthed high-pressure hose.



HAZARD: HIGH PRESSURE HOSE

The spray hose can develop leaks from wear, kinking and abuse. A leak can inject material into the skin. Inspect the hose before each use.

PREVENTION:

- High-pressure hoses must be checked thoroughly before they are used.
- Replace any damaged high-pressure hose immediately.
- Never repair defective high-pressure hoses yourself!
- Avoid sharp bends and folds: the smallest bending radius is about 20 cm.
- Do not drive over the high-pressure hose. Protect against sharp objects and edges.
- Never pull on the high-pressure hose to move the device.
- Do not twist the high-pressure hose.
- Use only compatible cleaning solutions.
- Lay the high-pressure hose in such a way as to ensure that it cannot be tripped over.



Only use approved original-high-pressure hoses in order to ensure functionality, safety and durability.



HAZARD: GENERAL

This product can cause severe injury or property damage.

PREVENTION:

- Follow all appropriate local, state, and national codes governing ventilation, fire prevention, and operation.
- Pulling the trigger causes a recoil force to the hand that is holding the spray gun. When cleaning, set the pressure control to the lowest possible pressure.
- Use only manufacturer authorized parts. User assumes all risks and liabilities when using parts that do not meet the minimum specifications and safety devices of the pump manufacturer.
- ALWAYS follow the material manufacturer's instructions for safe handling of chemicals.
- Clean up all material and solvent spills immediately to prevent slip hazard.
- Never leave this equipment unattended. Keep away from children or anyone not familiar with the operation of airless equipment.
- Device (main unit and spray hose) weighs in excess of 36 kg. Three-person lift is required.
- The device and all related liquids must be disposed of in an environmentally friendly way.

1.2 ISOCYANATE (ISO) CONDITIONS



Important Information Regarding Two-Component Material. Read before using the equipment.

ISOCYANATE (ISO) CONDITIONS

- Use only Methyldiisocyanates (MDI).
- Spraying materials that contain isocyanates (ISO) creates mists, vapors and atomized particulates that are potentially harmful.
- Be familiar with the spray material's SDS in order to understand specific hazards and necessary precautions that are related to the use of spray materials containing isocyanates.
- Provide extensive exhaust and fresh air introduction to keep the air within the spray area free from harmful isocyanate vapors. If sufficient ventilation is not available, a supplied-air respirator must be available to everyone in the work area.
- **AVOID ANY BARE-SKIN CONTACT WITH ISOCYANATES.** To prevent contact with isocyanates, all persons located within the spray area must be wearing the appropriate protective equipment, including chemically impermeable gloves, boots, aprons and goggles.

MATERIAL IGNITION

- Some materials may become self-igniting if applied too thickly. Read material manufacturer's warnings and material SDS.

KEEP SPRAY COMPONENTS SEPARATE

- Cross-contamination of individual spray materials can result in cured material in fluid lines which can cause severe injury and/or damage to the equipment.
- To prevent cross-contamination of the equipment wetted parts, **NEVER** interchange Component A (isocyanate) parts with Component B (resin) parts.

MOISTURE SENSITIVITY

Isocyanates (ISO) are catalysts used in two-component foam coatings. ISO will react with moisture (such as humidity) to form small, hard abrasive crystals. These crystals will then contaminate the fluid. Eventually a film will form on the fluid surface and the ISO will begin to gel, increasing in viscosity. Fluid contaminated with partially cured ISO, if used, will reduce spray performance and the overall life of the component wetted parts.



The amount of film formation and the rate of crystallization varies depending upon the blend of ISO, the humidity and the temperature.

PREVENTION:

- NEVER store ISO in an open container.
- Use ONLY the moisture-proof hoses specifically designed for ISO that are supplied with your system.
- Never flush reclaimed solvents through the system. Reclaimed solvents can contain moisture. Always keep solvent containers closed when not being used to prevent moisture contamination.
- Never use solvent on one side if it has been contaminated from the other side.
- Always lubricate threaded parts with ISO pump oil or grease when reassembling.

CHANGING MATERIALS

- When changing spray materials, thoroughly flush the equipment multiple times to ensure that it is fully clean.
- Always clean the fluid inlet strainers after flushing.
- Check with your material manufacturer for chemical compatibility.
- Most materials use ISO with Component A, but some use ISO with Component B.
- Epoxies often have amines (hardener) with Component B. Polyureas often have amines with Component B (resin).

FOAM RESINS WITH 245FA BLOWING AGENT

Some blowing agents will froth at temperatures above 90° F (33°C) when not under pressure, especially if agitated. To reduce frothing, minimize preheating in a circulation system.

1.3 ELECTRIC SAFETY

Electric models must be earthed. In the event of an electrical short circuit, earthing reduces the risk of electric shock by providing an escape wire for the electric current. Connection to the mains only through a special feed point, e.g. through an error protection installation with INF < 30 mA.

	<p>DANGER — Work or repairs at the electrical equipment may only be carried out by a skilled electrician. No liability is assumed for incorrect installation. Switch the unit off. Before all repair work, unplug the power plug from the outlet.</p>
	<p>Danger of short-circuits caused by water ingressing into the electrical equipment. Never spray down the unit with high-pressure or high-pressure steam cleaners.</p>

OPERATING TEMPERATURE

This equipment will operate correctly in its intended ambient, at a minimum between +10°C and +40°C.

RELATIVE HUMIDITY

The equipment will operate correctly within an environment at 50% RH, +40°C. Higher RH may be allowed at lower temperatures.

Measures shall be taken by the Purchaser to avoid the harmful effects of occasional condensation.

ALTITUDE

This equipment will operate correctly up to 2100 m above mean sea level.

TRANSPORTATION AND STORAGE

This equipment will withstand, or has been protected against, transportation and storage temperatures of -25°C to +55°C and for short periods up to +70°C.

It has been packaged to prevent damage from the effects of normal humidity, vibration and shock.

2 GENERAL DESCRIPTION

The Helix LP Heated Spray Foam Proportioner is a dual component airless sprayer system that can be linked in order to spray multi-component fluids.

2.1 SYSTEM CONFIGURATIONS

The Helix LP Heated Spray Foam Proportioner is available in the following configuration(s) which is based upon hose length, electrical phases and the required power cord (not supplied). Refer to the chart below.

Model	Voltage (phase)	Amps	Hose Watts	System Watts	Heated Hose	Min. Heated Temp	Max Heated Temp	Max Flow (gal/min)	Min Spray Pressure	Max Spray Pressure	Cord Specification AWG (mm ²)
0138040	230V (1)	30	4600	6900	200' (61 m)	32°F	140°F	1.1	40 PSI	120 PSI	8 (8.4), 3 wire + ground
0138065	230V (1)	35	5800	8100	100' (30 m)	32°F	140°F	1.1	40 PSI	120 PSI	8 (8.4), 3 wire + ground



The spray gun provided with this system or sold individually is not Intertek approved.

2.2 MOUNTING DIAGRAM

i	The Helix LP System comes with hanging, L-style brackets for installation. All supplied brackets must be installed in a manner that will safely carry the weight of the unit.
i	Make sure the bracket system is securely mounted (preferably to a wall stud) and will support a minimum of 200 lbs.
i	The main unit of the system is very heavy. Mounting will require at least two people in order for it to be performed safely.

1. Install the included, 48" hanging bracket onto a wall at the desired height. Make sure the bracket is secured to the studs behind the wall, and that it is level.
2. Hang the main unit from the bracket using the clips on the rear of the unit (see inset, fig. 2).
3. Secure your L-style brackets directly underneath the main unit, leaving room for the rubber feet (fig. 2, item 5).
4. Place a rubber foot (fig. 2, item 5) on each of the mounting holes of the bracket system.
5. Align the holes on the bottom of the main unit with the rubber feet. Carefully set the unit onto the feet.
6. Using the 1 1/2-inch 5/16" bolts (1), thread the four bolts through the lock washer (2), flat washer (3) bracket (4), through the vibration isolators (5), and up into the welded nuts and tighten securely.

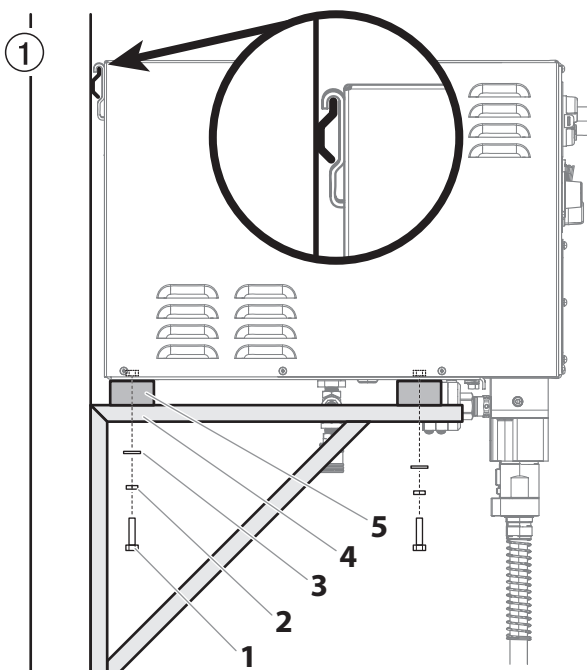

2.3 ELECTRICAL / GENERATOR REQUIREMENTS

i	It is recommended that the Helix System be used with a generator. This provides the flexibility with not having to use the public power grid. When connected to the public, low-voltage network, it is possible that an approval of the network operator is required. Check the regulations in your country and contact your network operator before connecting the unit to a public electricity grid.
i	The Helix LP System requires a 208-240V capacity. Make sure the power source is rated to this specification.
i	When working at altitudes above 2100m, check the generator manufacturer's specifications for power loss offset.

 Attention	If powering the Helix LP system with a generator, make sure the generator has ample power to run the system. An inadequate generator will cause RPM fluctuations in the Component Pump motors during usage and can cause damage.
----------------------	--

Follow the steps below to determining if your generator is able to supply sufficient power to the Helix LP system.

1. Perform this equation:

$$\text{System watts} \times 1.25 = \text{kVA (kilovolt / amperes)}$$
 System watts can be found on page 8.
2. If your generator's kVA rating is **higher** than what was determined in the equation above, the generator will be able to power the system.

If your generator's kVA rating is **lower** than what was determined in the equation above, the generator WILL NOT be able to power the system. A larger generator is required.

3 SYSTEM DESCRIPTION

3.1 SYSTEM DIAGRAM

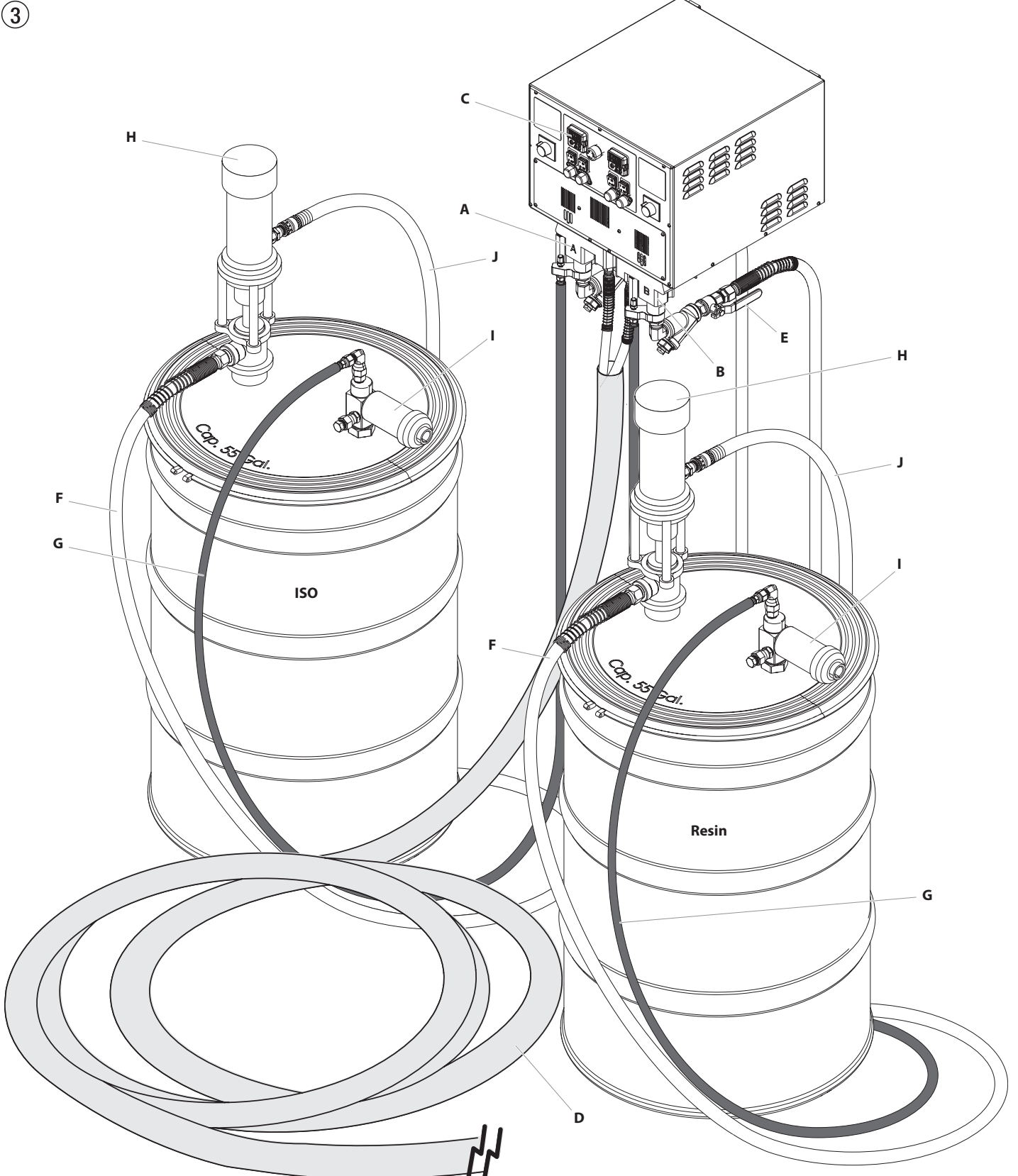

3.2 COMPONENT DESCRIPTION

	<p>This graphic does not show the system properly mounted or secured as required for use. Refer to section 2.2 for recommendations on mounting the Helix LP System. Mounting the system will require at least two people in order to be done safely.</p>
---	--

ITEM	DESCRIPTION	FUNCTION
A	Component Pump A	In a two-component system, Component Pump A typically pumps the ISO or activator material.
B	Component Pump B	In a two-component system, Component Pump B typically pumps the resin material.
C	Control Panel	The control panel contains all of the system controls that allow the sprayer to function properly, as well as being the main display panel that gives information about the system.
D	Dual heated hose	The dual heated hose delivers spray material from the two Component Pumps to the spray gun.
E	Inlet valves A and B side = 3/4" NPSM	The inlet valves allow material to be drawn from the material containers into the system. They can be turned off in order to prevent material from entering the system.
F	Supply hoses	The two supply hoses deliver fluid from the supply drums to the Component pumps.
G	Pressure relief hoses	These hoses act as the pressure relief mechanism for the LP system. Any excess fluid pressure will cause spray material to be automatically released into the pressure relief hoses and circulate back to the material containers.
H	Transfer pump	The two transfer pumps pump material from the supply containers, into the supply hoses and then to the Component Pumps. The transfer pumps are powered by an air compressor.
I	Desiccant dryer	The Desiccant dryers remove any moisture that is present in the air pockets left by the removal of material from the supply drums.
J	Transfer pump air hose	The transfer pump air hose delivers air from the compressor to the transfer pumps.

4 CONTROL PANEL

The control panel contains all of the system controls that allow the sprayer to function properly, as well as being the main display panel that gives information about the system.

i

Items 1 - 6 below are duplicated - one for each pump. If they are located on the left side of the panel, they serve the "A" side of the system. If they are located on the right, they serve the "B" side. If it is located in the middle, it serves the entire system.

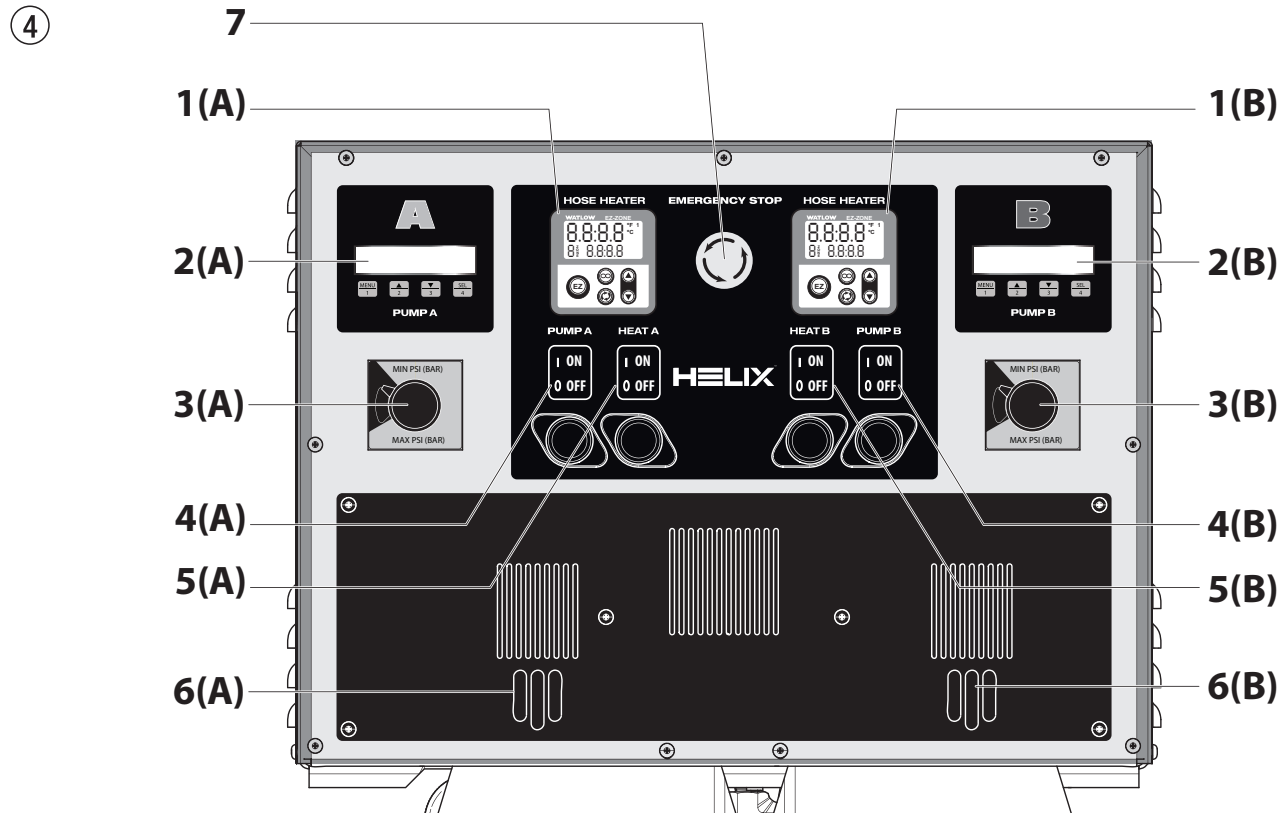

1	Heated hose temperature control	This panel regulates the spray material temperature for the applicable heated hose.
2	Control Displays	The displays show various menu screens that allow the user to customize and monitor pump operation using the function keys (1 - 4).
A	Master controller / A-side independent controller	When the component pumps are linked, the master controller controls both component pumps. When the component pumps are unlinked, this controls Component Pump A only.
B	B-side independent controller	When the component pumps are unlinked, this controls Component Pump B.
3	Component pump pressure control	Adjusts the pump pressure of the applicable Component Pump when unlinked. When the Component pumps are linked, the Component Pump B pump pressure control knob will control the pressure of both pumps.
4	ON/OFF switch, Component Pump	This switch turns the applicable Component Pump ON and OFF.
5	ON/OFF switch, hose heater	This switch turns the applicable hose heater ON and OFF.
6	Lubrication area	These slots in the front cover allow you to properly lubricate the component pumps as needed.
7	Emergency Shutoff	Pushing this button will instantly shut down the system. The relief valves installed below each component pump will then relieve any pressure left in the system.

4.1 HEATED HOSE TEMPERATURE CONTROL

i Refer to item 1 in section 4. (previous page). The heated hose temperature control maintains the temperature of the spray material as it passes through the heated hoses.

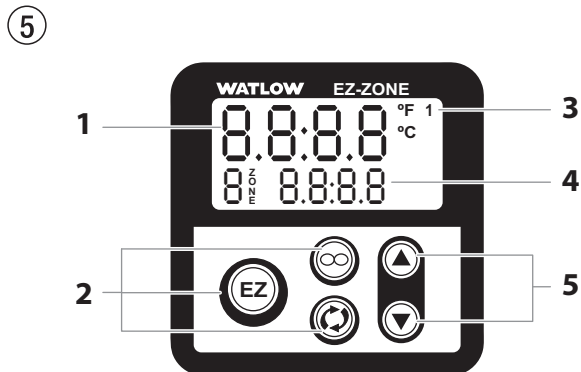

1	Display	Displays the current temperature of the heated hose set
2	Programming buttons	These are non-functioning factory programming buttons. Do not use.
3	Power indicator	The flashing or steady "1" indicates sufficient power is being delivered to the system's electrical relay.
4	Temperature setting	Shows the desired temperature of the heated hoses set by the operator
5	Temperature adjustment	These buttons will increase (▲) or decrease (▼) the temperature of the heated hose set. The temperature will change in increments of 1°F. Press and hold the button to increase the increments by 1°F and then 10°F.

i Refer to section 8.2 to review the controller error messages.

i Decreased voltage under 230V AC may increase initial heat time.

4.2 COMPONENT PUMP PRESSURE CONTROL

i Refer to item 2 in section 4. (previous page). The following items control the pressure of the individual Component Pumps.

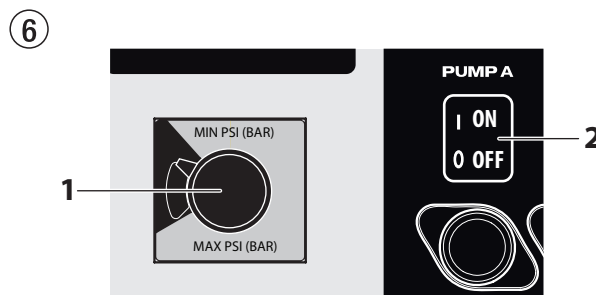

1	Pressure control knob	Adjusts the pump pressure of the applicable Component Pump when unlinked. When Component pumps are linked, the (A) pump pressure control knob will control the pressure of both pumps.
2	Component Pump ON/OFF switch	Switches the Component Pump ON and OFF.

PRESSURE CONTROL KNOB SETTINGS

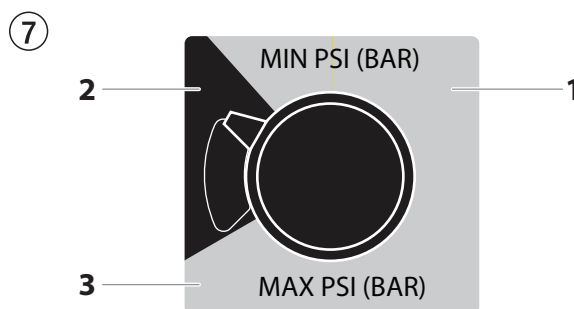

1	Minimum pressure setting
2	Black zone – no pressure generation
3	Maximum pressure setting

4.3 CONTROL DISPLAYS

i Refer to item 2 in section 4. The graphic below applies to both the Component Pump (A) and Component Pump (B).

The Control Displays increase the functionality of the applicable Component Pump.

It consists of a display (1) and four function keys (2). The display shows various menu screens that allow the user to customize and monitor sprayer operation using the function keys.

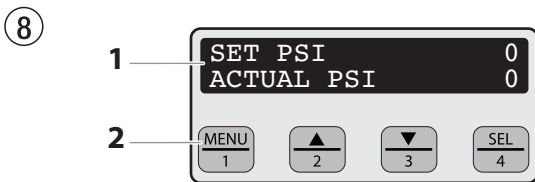

- i** When both component pumps are turned ON, the system will automatically link the two Component Pumps after 10 seconds. This means the Component Pump (B) control display will be controlled by the Component Pump (A) control display. When the component pumps are linked, the Component Pump (B) control display keys are disabled and will only be functional when the two Component Pumps are unlinked (see "Status Screen").
- i** The pressure control knob overrides the Control Display settings. Anytime the pressure control knob is turned, the sprayer pressure will change accordingly.

FUNCTION KEYS

The function keys are numbered 1–4. Each key is labeled with an additional function as well.

#1/Menu Key	Pressing the #1 key scrolls through the available menu screens or performs a function described on the active menu screen.
#2/▲ Key	Pressing the #2 key performs a function described on the active menu screen or increases a value.
#3/▼ Key	Pressing the #3 key performs a function described on the active menu screen or decrease a value.
#4/Select Key	Pressing the #4 key selects the active menu screen or performs a function described on the active menu screen.

MENU SCREENS

Several menu screens are available for the user to customize and monitor sprayer operation. They include Main Screen, Vis-Comp (Viscosity Compensation)*, Status* Alarm Range*, Alarm Status*, Total Cycles*, Job Cycles*, Unit Serial #, Timers, Job Timers, Service Time, Security Code*, and Prime.

i Screens noted with an asterisk (*) are screens that apply to Component Pump (B) only. All other screens apply to both (A) and (B) pumps.

Main Screen

The Main Screen is the default screen for the control system at sprayer startup.



Pressing the #2 key switches between PSI, Bar, and MPa units of measure. Press the #1 key to scroll through the remaining menu screens.

(B) Pump Only - The "L-" before the "Set PSI" text on the Main Screen indicates that the two Component Pumps are linked.



Vis-Comp (Viscosity Compensation) Screen*

The Vis-Comp screen on the (A) pump allows the user to see and/or adjust for slight differences in viscosity between the (A) pump material and the (B) pump material.

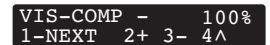

Pressing the #2 key will increase the spraying ratio in increments of 1% (up to 105%). Pressing the #3 key will decrease the spraying ratio in increments of 1% (down to 95%).

A Vis-Comp of 105% yields 5% **more** of (A) pump material.
A Vis-Comp of 95% yields 5% **less** of (A) pump material.

Status Screen*

The Status Screen shows the link status of the (A) pump and (B) pump.

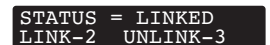

When turning the system on, the two pumps will automatically be linked, which means the (B) pump is controlled by the (A) pump.



When the Status Screen is showing, pressing the #3 key will unlink the two pumps, and the (A) pump and (B) pump will operate independently and the (B) pump control display keys will be enabled.

If the pumps have been unlinked, pressing the #2 key will link the two pumps back together, and the (B) pump will now be controlled by the (A).

Alarm Range Screen*

The Alarm Range Screen allows the user to adjust the allowable pressure discrepancy between the (A) and (B) pumps.

ALARM RANGE
+/- 80 PSI

Pressing the #2 key will increase the allowable pressure discrepancy by 10 psi. Pressing the #3 key will decrease the allowable pressure discrepancy by 10 psi. The range is 200 psi - 50 psi.

Alarm Status Screen*

The Alarm Status Screen allows the user to switch ON or OFF the internal alarm that alerts the user to a non-allowable pressure imbalance.

ALARM STATUS: OFF
ON-2 OFF-3 EXT-4

Pressing the #2 key will turn the alarm ON. Pressing the #3 key will turn the alarm OFF.

	<p>If a pressure imbalance is detected in the system with the alarm status set to ON, the system will automatically shut down and the display will show a PSI Imbalance. Refer to Control Display Error Messages.</p>
---	---

Total Cycles Screen*

The Total Cycles Screen shows the total number of piston cycles a component pump has performed during its lifetime.

TOTAL CYCLES
MENU-1 SELECT-4

Job Cycles Screen*

The Job Cycles Screen shows the total number of piston cycles a component pump performs during a spray job.

JOB CYCLE
MENU-1 SELECT-4

Pressing the #3 key will reset the cycle count to zero. Pressing the #1 key will bring the control panel back to the Main Screen.

CYCLES
MENU-1 XXXX
RESET-3

Cycles Per Minute (CPM) Screen

The Cycles Per Minute (CPM) screen can be accessed from the main menu by pressing the #4 key. This screen will show the speed of the pump while running.

CPM X
HALL CMD X

Unit Serial # Screen

The Unit Serial # screen shows the sprayer's serial number.

UNIT SERIAL #
MENU-1 SELECT-4

To select the Unit Serial # screen, press the #4 key.

SER # XXXXXXXXXXXX
MENU-1

Timers Screen

The Timers screen shows the total time the sprayer has been turned on as well as the total time the sprayer has been running (pumping).

TIMERS
MENU-1 SELECT-4

To select the Timers screen, press the #4 key.

ON TIME XXXX
RUN TIME XXXX

Job Timers Screen

The Job Timers screen allows the user to reset the "ON TIME" and "RUN TIME" to track time on specific jobs.

JOB TIMERS
MENU-1 SELECT-4

To select the Job Timers screen, press the #4 key. "JOB ON" screen will appear. Press #3 to reset. Press #1 to continue to "JOB RUN" screen. Press #3 to reset. Press #1 to scroll through the remaining menu screens.

JOB ON X
MENU-1 RESET-3

JOB RUN X
MENU-1 RESET-3

Service Time Screen

The Service Time screen allows the user to set a service time interval (in hours). Below the set time, the screens shows the current amount of hours on the sprayer since the last activation of the service timer. To select the Service Timer screen, press the #4 key.

SERVICE TIME
MENU-1 SELECT-4

To set the service time, press the #2 (up) and/or the #3 (down) keys to the desired time (run hours will increase/decrease in increments of 1 for each time you press a key).

SERVICE @ XX
RUN HOURS XX

When the service time interval is set and met by the run hours, the display will show a "Service Required" screen. The pump will remain functional. To return to the Main Screen, press the #1 key. Doing so will reset the "Service @" and "Run Hours" displayed on the Service Screen back to 0.

Security Code Screen*

The Security Code screen allows the user to set a four digit security code to prevent unauthorized use of the sprayer. If a security code has been set, the control system display will ask for the code at startup. If the correct code is entered, the display will show the Main Screen and the sprayer will operate. If the wrong code is entered, the display will continue to ask for the correct code and the sprayer will be disabled. To set or change the security code, press the #2 key.

SECURITY CODE
MENU-1 CHANGE-2



If the sprayer is new, no security code is set and the Main Screen will appear at startup. When setting a security code for the first time, the “Enter Old Code Number” screen will appear, and you will need to enter “1111”.

Enter the old security code number to access the screen that allows the code change. If the wrong code is entered, the display will continue to ask for the correct code and the security code cannot be changed.

ENTER OLD CODE

Enter the new security code. Once the new code is entered, the display will automatically ask that the new code be re-entered for verification. If the same new code is re-entered, the display will confirm that the new code has been accepted and return to the Main Screen. If the new code is re-entered incorrectly, the display will return to the “Enter New Code Number” screen and the process will repeat.

ENTER NEW CODE
NUMBER XXXX

RE-ENTER NEW
NUMBER XXXX

NEW CODE NUMBER
ACCEPTED

If you forget or misplace your security code, you can call Titan customer service for assistance.



To inactivate the Anti-Theft Digital Lockout security function, enter “1111” at the “Enter New Code Number” screen (this is the default code that leaves the sprayer unlocked). As a result, the Main Screen will appear at sprayer startup.

4.4 CONTROL DISPLAYS ERROR MESSAGES

The following error message screens appear whenever the Control Display detects a problem with the system. Once a problem occurs and the error message appears, the system will shut down.



Before proceeding, follow the Pressure Relief Procedure outlined in this manual. Additionally, follow all other warnings to reduce the risk of an injection injury, injury from moving parts or electric shock. Always unplug the system before servicing!

Check Transducer Screen

The Check Transducer screen appears when the transducer has become disconnected or is defective. Take the sprayer to a Titan authorized service center for repair.

CHECK
TRANSDUCER

Check Potentiometer Screen

The Check Potentiometer screen appears when the potentiometer has become disconnected or is defective. Take the sprayer to a Titan authorized service center for repair.

CHECK
POTENTIOMETER

Low Voltage Screen

The Low Voltage screen appears when the sprayer shuts down because of low input voltage. Check the power supply and correct the problem. Restart the system.

LOW
VOLTAGE

High Motor Temperature Screen

The High Motor Temperature screen appears when the temperature of the motor has risen too high. Take the sprayer to a Titan authorized service center for repair.

HIGH MOTOR
TEMPERATURE

High Mechanical Load

The High Mechanical Load screen appears when the sprayer shuts down because of high current or when the sprayer goes into current fold back mode. Take the sprayer to a Titan authorized service center for repair.

HIGH MECHANICAL
LOAD

PSI Imbalance

The PSI Imbalance screen appears when there is a non-allowable pressure discrepancy between the (A) and (B) pumps while linked. If a PSI imbalance occurs, turn both pressure control knobs to MIN, and press the #3 key to unlink the two pumps. Once the pumps are unlinked, press the #1 key to return to the Main Screen.

PSI IMBALANCE
UNLINK 3

5 SETUP

	<p>In order to prevent accidental startup, make sure the system's power cord is not connected during setup, until instructed to do so.</p>
	<p>Make sure the air pressure supply is shut off while connecting any air hoses to the air supply.</p>

5.1 LOCATE THE SYSTEM

1. Locate the system on a level surface. Refer to dimensions in section 2.2 for mounting hole dimensions.
2. Mount in a dry area.
3. For best results, the machine should be bolted into place.

5.2 CONNECT THE MATERIAL SUPPLY HOSES

	<p>The material drums will provide spray material to the component pumps via transfer pumps with supply hoses. Adequate air pressure to the transfer pumps is needed to get material to flow.</p>
--	---

Refer to section 3.1 for the corresponding illustrations to the steps below.

1. Arrange the material drums according to the following:
 - a. With certain exceptions, the "A" component (hardener) should be located on the "A" side of the system.
 - b. With certain exceptions, the "B" component (resin) should be located on the "B" side of the system.
2. Make sure the valve handles on the inlet valves for both Component pumps are in the OFF position (see fig. 9).

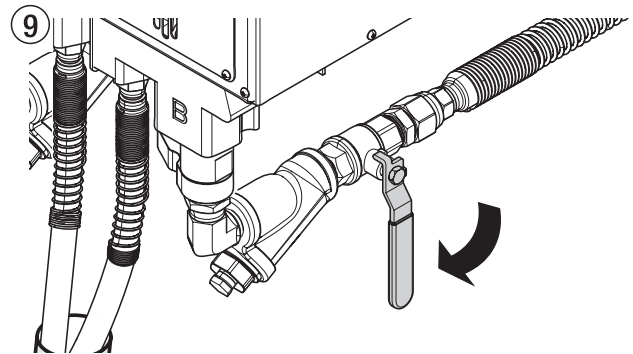

3. Attach one end of the feed hose to the inlet valve of Component pump A. Repeat for Component pump B with another hose.
4. Connect the other end of each hose to their appropriate material container transfer pump. (i.e. the "A" hose should run from the Component pump A to the material supply drum "A" transfer pump").
5. Connect the supply air hoses to the material drum transfer pumps. Make sure the air shutoff valve on the transfer pump is in the OFF position.

5.3 CONNECT THE AIR SUPPLY

i The system must be connected to an air compressor that will provide the necessary air power for the spray gun. If there is no air supply, there will not be sufficient pressure to spray.

1. Connect the air supply hose to the fitting located underneath the main unit.

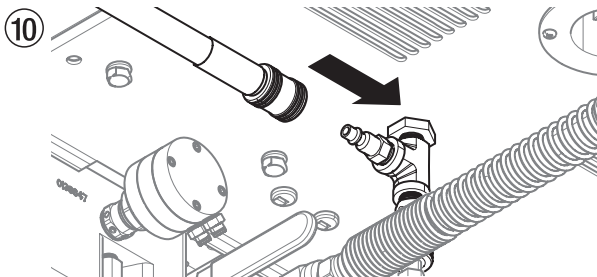

5.4 CONNECT THE HEATED HOSES

Attention The heated hose assembly and dual whip hose come pre-installed with the system and should not be removed or disassembled unless it is being completely replaced.

i Refer to the Surefire™ Helix LP Heated Hose Manual included with your system.

1. Make sure the heated hose and air hose ball valves are closed.
2. Attach the whip hoses to the fittings on the spray gun.
 - a. Secure the "A" hose to the "A" side (red) of the spray gun hose.
 - b. Secure the "B" hose to the "B" side (blue) of the spray gun hose.
 - c. Secure the air supply hose to the air hose (white) of the spray gun.
3. Tighten all hose connections with a wrench. Torque to 18 ft.-lbs.

5.5 CONNECT THE ELECTRICAL CORD

i A 230V power cord is not included with the system. Make sure a grounded, 230V outlet is available in order to power the system. A Twistlock power plug (P/N 0522597) is included with the unit

i It is recommended that the Helix System be used with a generator. This provides the flexibility with not having to use the public power grid. When connected to the public, low-voltage network, it is possible that an approval of the network operator is required. Check the regulations in your country and contact your network operator before connecting the unit to a public electricity grid.

Power Cord Connector Requirements	
Connector	Twistlock
AMP	50
Number of Poles	3
Number of Wires	4
Phases	1
Voltage	125 / 250 VAC
Recommended Manufacturer	Hubbell P/N CS-6364C

i If using a generator to power the system, refer to section 2.3 prior to plugging in the power cord.

1. First plug the adapter end of the power cord into the power cord port located on the bottom side of the unit.
2. Plug the other end of the power cord into a grounded, 230V outlet.

5.6 GROUND THE SYSTEM



Proper grounding (earthing) is important. The passage of some materials through the fluid hose will build up a static electric charge, which if discharged, could ignite solvent vapors present and create an explosion.

Component	Grounding Method
System	The system and heated hoses are grounded through the power cord.
Spray Gun	The spray gun is grounded through the whip hose ground wire. Do not spray without using the whip hose.
Fluid Supply Chambers	Follow the local code.
Object being sprayed	Follow the local code.
Waste Containers	Follow the local code. Only use metal containers placed on a grounded surface when flushing the system. Do not place metal waste containers on paper or cardboard surface. A non-conductive surface such as these can interrupt grounding continuity.



While flushing or relieving system pressure, ground the gun by holding it against the edge of the metal container. Failure to do so may lead to a static electric discharge, which may cause a fire.

5.7 LUBRICATE THE COMPONENT PUMPS

1. Fill both upper seal retainer reservoirs with DOP (Diocetylphthalate) or compatible plasticizer (Fig. 11).



DOP (Diocetylphthalate) or a compatible plasticizer prevents increased wear and tear to the packings and will keep spray material from crystallizing on the fluid section.

2. Repeat this procedure after each use.

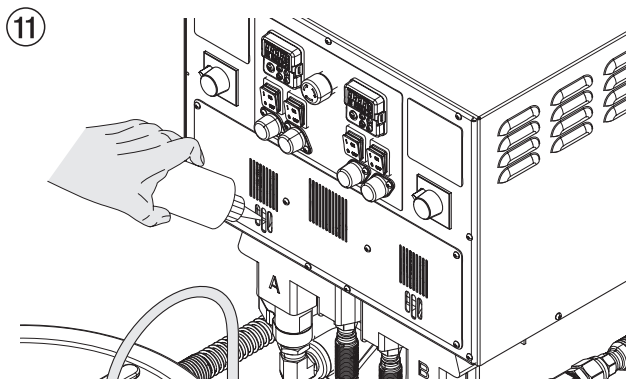

6 OPERATION

 <p>Attention</p>	<p>Prior to startup, make sure the generator has fuel. Running out of fuel will cause electrical fluctuations in the system that could result in damage to the electrical components of the system.</p>
--	---



6.1 STARTUP

1. If using a generator, make sure the main breaker on the generator is in the OFF position.
2. If using a generator, start the generator. Allow it to run to full power. **DO NOT** use the "IDLE" feature of the generator.
3. If using an air compressor to provide air power to the spray gun, start the compressor, making sure the bleed valve is in the closed position on the compressor.
4. Turn the breaker on the generator to ON. Switch both of the Component Pump ON/OFF switches to ON. (these are the outermost ON/OFF switches located on the control panel).

 <p>Attention</p>	<p>Do not turn on the hose heater ON/OFF switches ON yet. Turning the hose heaters on when there is no fluid in the hoses can cause damage to the hoses.</p>
--	--

5. Make sure the heated hose and air supply hose are attached securely to the spray gun. Each connection needs to be secure in order to avoid air or material leakage.
6. Open the fluid inlet valves. Check for leaks.
7. Open the air valves on the material drum transfer pumps. This will allow the material to slowly recirculate through the pump, return hose, and back to the material drum
8. Purge the fluid from each hose separately by turning on the chemical valve located at the end of each whip hose and triggering the spray gun with a new spray nozzle. A new spray nozzle should be used for each material..
9. The system is now primed and you are ready to set the material temperature.

6.2 SET TEMPERATURE

	<p>Refer to section 4. to review temperature controls.</p>
	<p>Equipment surfaces can become hot. To avoid severe burn injury:</p> <ol style="list-style-type: none"> 1) Do not touch hot fluid or equipment. 2) Allow equipment to cool completely before coming into contact with it. 3) Wear gloves when dealing with temperatures in excess of 110°F (43°C)

1. Set the temperature of the heated hoses (repeat each of the following steps for both A and B hoses):
 - a. Switch the heated hose ON/OFF switches to ON (these are the switches immediately on either side of the heater block switch in the middle of the control panel).
 - b. Using the heated hose controls, set the heated hoses to the desired temperature. Press the (▲) button until the bottom set of numbers (1) shows the desired temperature.
 - c. The temperature settings of the heated hoses can also be adjusted to balance spraying pressures as well as the desired Viscosity Compension (Vis-Comp).

	<p>Adjusting the hose heat should ONLY be a secondary method of achieving the correct Vis-Comp. Use the Vis-Comp Screen on the Control Display first.</p>
---	---

6.3 SPRAYING

	Refer to the safety information in the beginning of this manual for injury prevention guidelines.
---	---

1. Make sure the air valve on the spray gun (if present) is open all the way to allow maximum air flow.
2. Verify that the temperature readings are showing the desired temperatures.
3. Verify pressure readings:
For each component pump, go to the Control Display Main Screen on the control panel.

	The pressures shown on the Control Display Screens should be within 25 PSI. If pressure is unbalanced, unlink the pumps, and then adjust the pressure to desired balanced pressure. Once pressure is balanced, re-link the pumps.
---	---

 Attention	NEVER trigger the spray gun if the pressure readings are unbalanced.
--	---

4. Test your spray on a piece of scrap wood or cardboard. Adjust pressure and temperatures as necessary to achieve desired results.

6.4 PRESSURE RELIEF PROCEDURE

	Perform the Pressure Relief Procedure when shutting down for any reason.
---	--

1. Turn the pressure control knob for both component pumps to minimum.
2. Close the fluid inlet valves on both component pumps so no more fluid enters the system.
3. Trigger the spray gun to relieve pressure in the spray hoses. Verify that the pressure on both pumps drops to 0.

 Attention	Do not disconnect air supply from the spray gun. Air should flow through the system until it is completely shut down.
---	---

7 SHUTTING DOWN



It is important to the system's electrical reliability to maintain steady electrical voltage during shutdown. Failure to follow these procedures can cause voltage fluctuations that can damage the equipment and void the warranty.

1. Perform the Pressure Relief Procedure (section 6.4).
2. Turn both hose heater A and B ON/OFF switches to OFF.
3. Switch off the air compressor and any other auxiliary equipment, if being used.
4. Open the bleed valve on the air compressor tank in order to relieve pressure and remove any water that may have formed in the tank.
5. Close the fluid inlet valves on the supply hoses (handles should be perpendicular to the valve).
6. Turn the Component (A) and Component (B) inlet valve handles to the closed position (handle should be 90° to the valve).
7. Shut down the nitrogen tank as required.



7.1 PARKING



Perform the following steps on the (A) Component Pump ONLY unless otherwise specified. The following must be done in order to prevent spray material build-up on the (A) side Component Pump fluid section.

1. Turn the Component Pump A pressure control knob fully counterclockwise to minimum setting.
2. Close the fluid inlet valves on both component pumps so no more fluid enters the system.
3. Turn the Component Pump B ON/OFF switch to OFF.
4. Make sure the Component Pump A ON/OFF switch is still ON.
5. Wait several seconds until the "COMM LOST" screen appears on the Component Pump A display. When it appears, press the #3 button to unlink the two Component Pumps.
6. Make sure the crankshaft/slider assembly of the A pump is in the bottom, dead-center position:
 - a. Turn the Component Pump A pressure control knob slightly clockwise until the pump begins to run. Through the vents in the front cover on the main unit, observe the crankshaft/slider assembly as it moves.
 - b. Turn the knob quickly to minimum to stop the crankshaft/slider. Note the position of the crankshaft/slider.
 - c. Repeat as necessary until the crankshaft/slider assembly stops at the bottom, dead center position.
 - d. Once bottom, dead-center position is achieved, Component Pump A is parked. It is not necessary to repeat this procedure for Component Pump B.
7. Turn the Component Pump A ON/OFF switch to OFF.
8. Fill both upper seal retainer reservoirs with DOP (Diocetylphthalate) or compatible plasticizer (see Fig. 1).

7.2 FLUSHING

	Flush the system in a well-ventilated area. Do not turn on hose heaters when flushing with flammable solvents.
	If the new Isocyanate being introduced is compatible with Polyol, it is not necessary to flush the (A) side.

1. Flush out the old fluid with new fluid, or flush the old fluid with a compatible solvents prior to introducing a new fluid (check with the old fluid manufacturer in order to determine a compatible flushing solvent).
2. Always use the lowest possible pressure when flushing the sprayer. Make sure the Component Pump pressure control knobs are turned as far counterclockwise as possible in the "MIN PSI" zone.
3. Use only moisture-free solvents when flushing the system.

8 TROUBLESHOOTING

8.1 COMPONENT PUMPS

Problem	Cause	Solution
A. The unit will not run.	<ol style="list-style-type: none"> 1. The unit is not plugged in to a power source. 2. Blown fuse. 3. The pressure is set too low (pressure control knob set at minimum setting does not supply power to unit). 4. Faulty or loose wiring. 5. Excessive motor temperature. 6. ON/OFF switch is defective. 	<ol style="list-style-type: none"> 1. Plug the power cord into a grounded, 230V outlet. 2. Replace the fuse. 3. Turn the pressure control knob clockwise to supply power to the unit and increase the pressure setting. 4. Inspect or take to an authorized service center. 5. Allow motor to cool. 6. Replace the ON/OFF switch.
B. The unit will not build or maintain pressure.	<ol style="list-style-type: none"> 1. The pressure control knob is not set properly. 2. Air leak in material feed hoses. 3. There is external fluid leak. 4. There is an internal fluid section leak (packings are worn and/or dirty, valve balls are worn). 5. Worn valve seats 6. Motor powers but fails to rotate 7. Fluid supply valves not open. 8. Nitrogen pressure too low. 9. Air pressure not sufficient. 10. Defective pressure relief valve. 	<ol style="list-style-type: none"> 1. Turn the pressure control knob clockwise to increase the pressure setting. 2. Check the inlet valve / feed hose connection. Tighten or wrap the threads with Teflon tape. 3. Check for external leaks at all connections. Tighten connections, if necessary. 4. Clean the valves and service the fluid section following the steps in section 9.3 and 9.4 in this manual. 5. Reverse or replace the valve seats following the steps in section 9.3 and 9.4 in this manual. 6. Take unit to a authorized service center. 7. Open the fluid supply valves. 8. Increase the air pressure to the material drum transfer pumps. 9. Increase the air compressor pressure. 10. Take the system to an authorized Titan service center for repair.
C. Fluid leakage at the upper end of the fluid section.	<ol style="list-style-type: none"> 1. The upper packings are worn. 2. The piston rod is worn. 	<ol style="list-style-type: none"> 1. Repack the pump following the steps in section 9.3 and 9.4 in this manual. 2. Replace the piston rod following the steps in section 9.3 and 9.4 in this manual.

8.2 HOSE HEATER CONTROLLER ERRORS

Problem	Cause	Solution
<p>A. Alarm will not clear or Reset with keypad or digital input.</p>	<ol style="list-style-type: none"> 1. Alarm latching is active 2. Alarm set to incorrect output 3. Alarm is set to incorrect source 4. Sensor input is out of alarm set point range 5. Alarm set point is incorrect 6. Alarm is set to incorrect type 7. Digital input function is incorrect 	<ol style="list-style-type: none"> 1. Reset alarm when process is within range or disable latching 2. Set output to correct alarm source instance 3. Set alarm source to correct input instance 4. Correct cause of sensor input out of alarm range 5. Set alarm set point to correct trip point 6. Set digital input function and source instance
<p>B. Alarm will not activate output.</p>	<ol style="list-style-type: none"> 1. Alarm silencing is active 2. Alarm blocking is active 3. Alarm is set to incorrect output 4. Alarm is set to incorrect source 5. Alarm set point is incorrect 6. Alarm is set to incorrect type 	<ol style="list-style-type: none"> 1. Disable alarm silencing, if required 2. Disable alarm blocking, if required 3. Set output to correct alarm source instance 4. Set alarm source to correct input instance 5. Set alarm set point to correct trip point 6. Set alarm type to correct type
<p>C. Alarm Error. Alarm status cannot be determined due to a lack of sensor input.</p> <p>ALE1 ALE2 ALE3 ALE4</p>	<ol style="list-style-type: none"> 1. Sensor improperly wired or open 2. Incorrect setting of sensor type 3. Calibration corrupt 	<ol style="list-style-type: none"> 1. Correct wiring or replace sensor 2. Match setting to sensor used 3. Check calibration of controller
<p>D. Alarm Low. Sensor input below low alarm set point.</p> <p>ALL1 ALL2 ALL3 ALL4</p>	<ol style="list-style-type: none"> 1. Temperature is less than alarm set point 2. Alarm is set to latching and an alarm occurred in the past 3. Incorrect alarm set point 4. Incorrect alarm source 	<ol style="list-style-type: none"> 1. Check cause of under temperature 2. Clear latched alarm 3. Establish correct alarm set point 4. Set alarm source to proper setting
<p>E. Alarm High. Sensor input above high alarm set point.</p> <p>ALH1 ALH2 ALH3 ALH4</p>	<ol style="list-style-type: none"> 1. Temperature is greater than alarm set point 2. Alarm is set to latching and an alarm occurred in the past 3. Incorrect alarm set point 4. Incorrect alarm source 	<ol style="list-style-type: none"> 1. Check cause of over temperature 2. Clear latched alarm 3. Establish correct alarm set point 4. Set alarm source to proper setting
<p>F. Error Input. Sensor does not provide a valid signal to controller</p> <p>Er..1</p>	<ol style="list-style-type: none"> 1. Sensor improperly wired or open 2. Incorrect setting of sensor type 3. Calibration corrupt 	<ol style="list-style-type: none"> 1. Correct wiring or replace sensor 2. Match setting to sensor used 3. Check calibration of controller
<p>G. Limit will not clear or Reset with keypad or digital input</p>	<ol style="list-style-type: none"> 1. Sensor input is out of limit set point range 2. Limit set point is incorrect 3. Digital input function is incorrect 	<ol style="list-style-type: none"> 1. Correct cause of sensor input out of limit range 2. Set limit set point to correct trip point 3. Set digital input function and source instance
<p>H. Limit Error. Limit status cannot be determined due to a lack of sensor input, limit will trip.</p> <p>L..E1</p>	<ol style="list-style-type: none"> 1. Sensor improperly wired or open 2. Incorrect setting of sensor type 3. Calibration corrupt 	<ol style="list-style-type: none"> 1. Correct wiring or replace sensor 2. Match setting to sensor used 3. Check calibration of controller
<p>I. Limit Low. Sensor input below low limit set point.</p> <p>L..L1</p>	<ol style="list-style-type: none"> 1. Temperature is less than limit set point 2. Limit outputs latch and require Reset 3. Incorrect alarm set point 	<ol style="list-style-type: none"> 1. Check cause of under temperature 2. Clear limit 3. Establish correct limit set point
<p>J. Limit High. Sensor input above high limit set point.</p> <p>L..H1</p>	<ol style="list-style-type: none"> 1. Temperature is greater than limit set point 2. Limit outputs latch and require Reset 3. Incorrect alarm set point 	<ol style="list-style-type: none"> 1. Check cause of over temperature 2. Clear limit 3. Establish correct limit set point

<p>K. Loop Open Error. Open Loop Detect is active and the process value did not deviate by a user-selected value in a user specified period with PID at 100%.</p> <p>LP.O1 LP.O2</p>	<ol style="list-style-type: none"> 1. Setting of Open Loop Detect Time incorrect. 2. Setting of Open Loop Detect Deviation incorrect. 3. Thermal loop is open. 4. Open Loop Detect function not required but activated. 	<ol style="list-style-type: none"> 1. Set correct Open Loop Detect Time for application. 2. Set correct Open Loop Deviation value for application. 3. Determine cause of open thermal loop: misplaced sensors, load failure, loss of power to load, etc. 4. Deactivate Open Loop Detect feature.
<p>L. Loop Reversed Error. Open Loop Detect is active and the process value is headed in the wrong direction when the output is activated based on deviation value and user-selected value.</p> <p>LP.R1 LP.R2</p>	<ol style="list-style-type: none"> 1. Setting of Open Loop Detect Time incorrect. 2. Setting of Open Loop Detect Deviation incorrect. 3. Output programmed for incorrect function. 4. Thermocouple sensor wired in reverse polarity. 	<ol style="list-style-type: none"> 1. Set correct Open Loop Detect Time for application. 2. Set correct Open Loop Deviation value for application. 3. Set output function correctly. 4. Wire thermocouple correctly (red wire is negative).
<p>M. Ramping Error. Controller is ramping to new set point.</p> <p>RP 1 RP 2</p>	<ol style="list-style-type: none"> 1. Ramping feature is activated. 	<ol style="list-style-type: none"> 1. Disable ramping feature if not required.
<p>N. Autotuning Error. Controller is autotuning the control loop.</p> <p>EUN1 EUN2</p>	<ol style="list-style-type: none"> 1. User started the autotune function. 2. Digital input is set to start autotune. 	<ol style="list-style-type: none"> 1. Wait until autotune completes or disable autotune feature. 2. Set digital input to function other than autotune, if desired.
<p>O. No heat/cool action. Output does not activate load.</p>	<ol style="list-style-type: none"> 1. Output function is incorrectly set. 2. Control mode is incorrectly set. 3. Output is incorrectly wired. 4. Load, power or fuse is open. 5. Control set point is incorrect. 6. Incorrect controller model for application. 	<ol style="list-style-type: none"> 1. Set output function correctly. 2. Set control mode appropriately (Open vs. Closed Loop). 3. Correct output wiring. 4. Correct fault in system. 5. Set control set point in appropriate control mode and check source of set point: remote, idle, profile, closed loop, open loop. 6. Obtain correct controller model for application.
<p>P. No display indication or LED illumination.</p>	<ol style="list-style-type: none"> 1. Power to controller is off 2. Fuse open 3. Breaker tripped 4. Safety interlock switch open 5. Separate system limit control activated 6. Wiring error 7. Incorrect voltage to controller 	<ol style="list-style-type: none"> 1. Turn on power 2. Replace fuse 3. Reset breaker 4. Close interlock switch 5. Reset limit 6. Correct wiring issue 7. Apply correct voltage, check part number

<p>Q. Process does not control to set point. Process is unstable or never reaches set point.</p>	<ol style="list-style-type: none"> 1. Controller not tuned correctly. 2. Control mode is incorrectly set. 3. Control set point is incorrect. 	<ol style="list-style-type: none"> 1. Perform autotune or manually tune system. 2. Set control mode appropriately (Open vs. Closed Loop). 3. Set control set point in appropriate control mode and check source of set point: remote, idle, profile, closed loop, open loop.
<p>R. Temperature runaway. Process value continues to increase or decrease past set point.</p>	<ol style="list-style-type: none"> 1. Controller output incorrectly programmed 2. Thermocouple reverse wired 3. Controller output wired incorrectly 4. Short in heater 5. Power controller connection to controller defective 6. Controller output defective 	<ol style="list-style-type: none"> 1. Verify output function is correct (heat or cool) 2. Correct sensor wiring (red wire negative) 3. Verify and correct wiring 4. Replace heater 5. Replace or repair power controller 6. Replace or repair controller
<p>S. Device Error. Controller displays internal malfunction message at power up.</p> <p>100 RETN</p>	<ol style="list-style-type: none"> 1. Controller defective 2. Miss wired input or ground loop 	<ol style="list-style-type: none"> 1. Replace or repair controller 2. Correct wiring or remove ground loop circuit
<p>T. Heater Error.</p> <p>H. ER</p>	<ol style="list-style-type: none"> 1. Current through load is above current trip set point. 2. Current through load is below current trip set point. 	<ol style="list-style-type: none"> 1. Check that the load current is proper. Correct cause of overcurrent and/or ensure current trip set point is correct. 2. Check that the load current is proper. Correct cause of undercurrent and/or ensure current trip point is correct.
<p>U. Current Error. Load current incorrect.</p> <p>C. ER</p>	<ol style="list-style-type: none"> 1. Short solid-state or mechanical relay. 2. Open solid-state or mechanical relay. 3. Current transformer load wire associated to wrong output. 4. Defective current transformer or controller. 5. Noisy electrical lines. 	<ol style="list-style-type: none"> 1. Replace relay. 2. Replace relay. 3. Route load wire through current transformer from correct output, and go to the Source Output Instance parameter (Setup Page, Current Menu) to select the output that is driving the load. 4. Replace or repair sensor or controller. 5. Route wires appropriately, check for loose connections, add line filters.
<p>V. Menus inaccessible. Unable to access:</p> <p>SET OPER FCTY PROF</p> <p>menus or particular prompts in Home Page.</p>	<ol style="list-style-type: none"> 1. Lockout or Security set to incorrect level 2. Digital input set to lockout keypad 3. Custom parameters incorrect 	<ol style="list-style-type: none"> 1. Check lockout setting in Factory Page 2. Change state of digital input 3. Change custom parameters in Factory Page
<p>W. EZ-Keys do not activate required function.</p>	<ol style="list-style-type: none"> 1. EZ-Key function incorrect 2. EZ-Key function instance not incorrect 3. Keypad malfunction 	<ol style="list-style-type: none"> 1. Verify EZ-Key function in Setup Menu 2. Check that the function instance is correct 3. Replace or repair controller
<p>X. Value too low to be displayed in 4 digit LED display.</p> <p>VAL.L</p>	<ol style="list-style-type: none"> 1. Incorrect setup 	<ol style="list-style-type: none"> 1. Check scaling of source data
<p>Y. Value too high to be displayed in 4 digit LED display.</p> <p>VAL.H</p>	<ol style="list-style-type: none"> 1. Incorrect setup 	<ol style="list-style-type: none"> 1. Check scaling of source data

9 SERVICING

	<p>Before proceeding, follow the Pressure Relief Procedure outlined previously in this manual. Additionally, follow all other warnings to reduce the risk of an injection injury, injury from moving parts or electric shock. Always unplug the system before servicing!</p>
	<p>All service instructions apply to both Component A and Component B pumps, unless otherwise specified. If ordering a new motor controller (Fig. 17, item 12), make sure to order it for the correct Component Pump (see "Drive Assembly" in the Spare Parts List section).</p>
	<p>Be sure and check for ground continuity following the replacement of any electrical components.</p>

9.1 REPLACING THE MOTOR ASSEMBLY

1. Disconnect the power cord.
2. Remove the screws (Fig. 14, item 1) that secure the top shroud (2) to the main unit. Remove the top shroud.
3. Remove the two large screws (3) and washers that secure the side bracket to the main unit. Remove the two small screws (4) that secure the side bracket to the center plate.

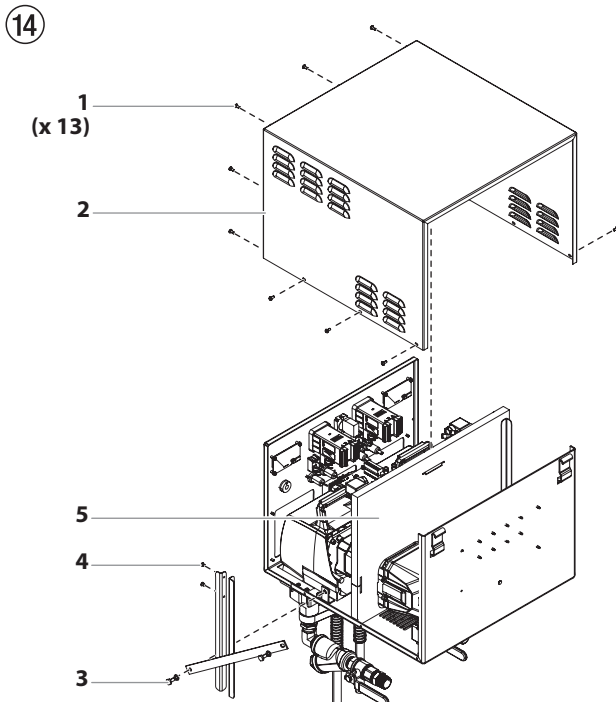

4. Disconnect the communication cable that connects the two motors.
5. Carefully remove the foam (5). Slide it towards the rear of the unit off of the component pump motors.
6. Disconnect all wires between the motor and the sprayer.
7. Disconnect the wires between the motor (Fig. 15, item 6) and the control panel.
8. Loosen and remove the two motor cover screws (7). Remove the motor cover (8)
9. Loosen and remove the two motor controller screws (9). Remove the motor controller (10).
10. Loosen and remove the four motor baffle screws (11). Remove the motor baffle (12).
11. Loosen and remove the four motor mounting screws (13). Pull the motor out (6) of the gearbox housing (14).
12. With the motor removed, inspect the gears in the gearbox housing for damage or excessive wear. Replace the gears, if necessary.
13. Install the new motor (6) into the gearbox housing.
14. Secure the motor with the four motor mounting (13) screws.
15. Reconnect the wires between the sprayer and the new motor (refer to the **Electrical Schematic**, section 9.7).
16. Place the baffle (12) over the end of the motor assembly. Secure with the four motor baffle screws (11).
17. Place motor controller (10) back into place behind the motor baffle (12). Secure with the two motor controller screws (9).
18. Reconnect all wires between the motor and sprayer.
19. Reconnect the wires between the motor and the control panel.
20. Place the motor cover (8) back over the motor controller. Secure with the two (7) motor cover screws.
21. Reconnect the communication cable to the two motor assemblies.
22. Replace the two large screws (Fig. 14, item 3) and washers that secure the side bracket to the main unit. Replace the two small screws (4) that secure the side bracket to the center plate.
23. Put the top shroud (2) back in place. Secure with the shroud screws (1).

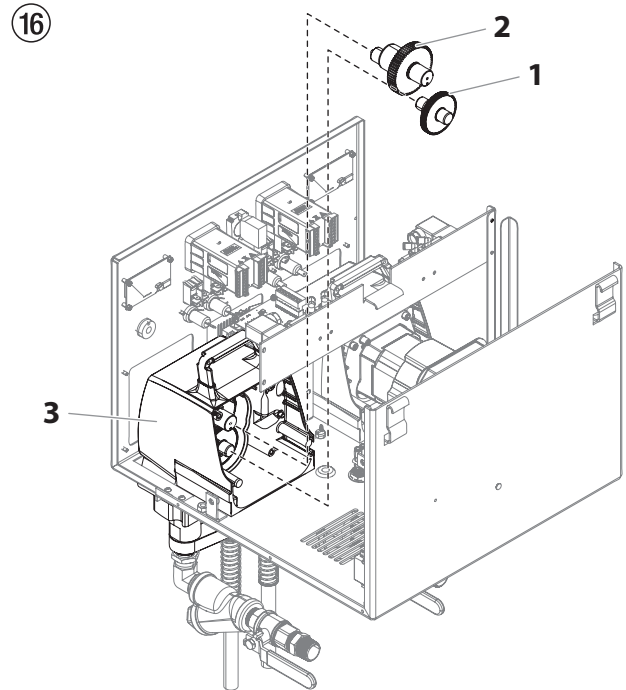
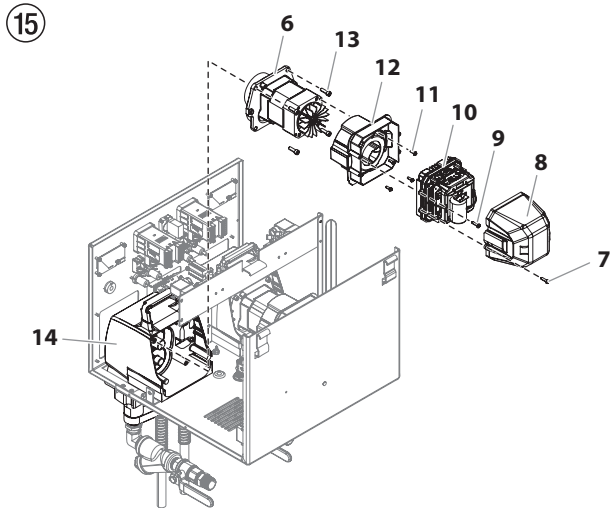

Make sure to check for grounding continuity after service is performed on any electrical components.
Use an ohmmeter to determine that there is continuity between accessible dead-metal parts of the product and the grounding blade of the attachment plug.



Make sure to check for grounding continuity after service is performed on any electrical components.
Use an ohmmeter to determine that there is continuity between accessible dead-metal parts of the product and the grounding blade of the attachment plug.

9.2 REPLACING THE GEARS (FIG. 18)

1. Follow steps 1-11 in **Replacing the Motor Assembly** to remove the motor.
2. Inspect the armature gear on the end of the motor for damage or excessive wear. If the gear is completely worn out, replace the motor assembly.
3. Remove and inspect the 2nd stage gear (1) for damage or excessive wear. Replace if necessary.
4. Remove and inspect the gear and crank assembly (2) for damage or excessive wear. Replace if necessary.
5. Inspect the front gear box assembly (3) for damage or excessive wear. If damaged or worn, replace the front gear box assembly.



Clean and refill the gear box cavity up to the rear face of each gear with Lubriplate (P/N 314-171).

6. Reinstall the motor into the gearbox housing.
7. Follow steps 13-23 in **Replacing the Motor Assembly** to replace the motor and control panel.

9.3 INLET AND OUTLET VALVE

1. Remove the four screws in the front cover and then remove the front cover.



Danger of crushing - do not reach with the fingers or tool between the moving parts.

2. The piston rod will need to be in the lower stroke position:
 - a. Turn the pressure control knob to minimum pressure. The Control Screen should say "PRIME".
 - b. Press the #1 key on the control panel. The "CREEP MODE" screen will now appear.
 - c. Slowly turn the pressure control knob clockwise to increase the pressure. The crankshaft/slider assembly will begin to move very slowly.
 - d. When it reaches the bottom, dead-center of its stroke, turn the pressure control knob back to minimum pressure. The crankshaft/slider assembly should stop.
3. Unplug the power plug from the outlet.
4. If you have a shutoff valve installed onto the bottom of the pump inlet (Fig. 17, item 1), remove it.
5. Unscrew the inlet valve housing (1) from the pump manifold.
6. Remove the lower seal (4), lower ball guide (5), spring (6) inlet valve ball (7), inlet valve seat (8) and O-ring (9).
7. Clean all the parts with the corresponding cleaning agent. Check the inlet valve housing (1), inlet valve seat (8) and inlet valve ball (7) for wear and replace the parts if necessary. If the worn inlet valve seat (8) is unused on one side, install it the other way round.

17

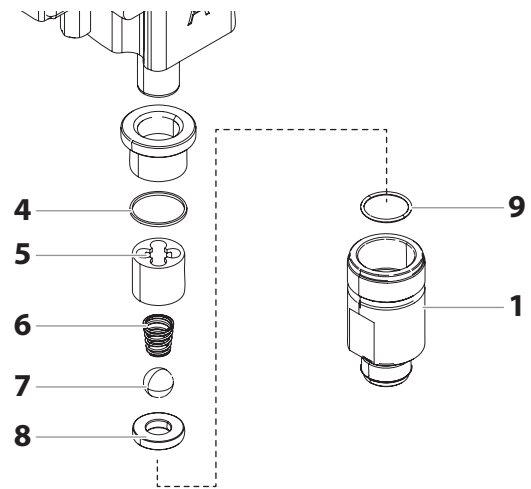

8. Unscrew outlet valve housing (Fig. 18, Item 10) from the piston (11) with adjusting wrench.
9. Remove the upper ball cage (12), crush washer (13), outlet valve ball (14), and outlet valve seat (15).
10. Clean all the parts with the corresponding cleaning agent. Check outlet valve housing (10), outlet valve seat (15), outlet valve ball (14), crush washer (13), and upper ball cage (12) for wear and replace parts if necessary. If the worn outlet valve seat (15) is unused on one side, install it the other way round.
11. Carry out installation in the reverse order. Lubricate O-ring (Fig. 17, Item 9) with machine grease and ensure proper seating in the inlet valve housing (Fig. 13, Item 1).

18

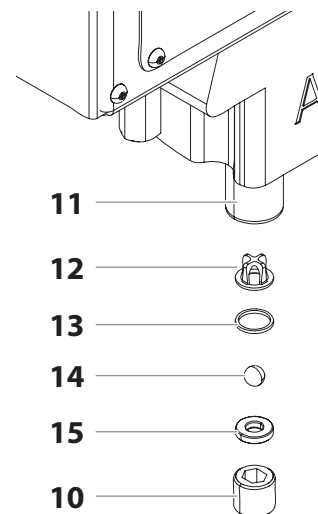

9.6 PACKINGS

1. Remove inlet valve housing in accordance with the steps in Chapter 9.3.
2. It is not necessary to remove the outlet valve.
3. Remove the screws that secure the front face plate onto the front of the main unit. Remove the face plate.
4. Disconnect the wiring for the heated hose on the same side as the component pump fluid section you are working on. Loosen the small screw on the appropriate relay and pull out the wire.
5. Unwrap the heated hoses at a distance of about 10 feet from the main unit.
6. Unscrew both cylinder head screws (Fig. 19, Item 1) from the pump manifold (2) with a 3/8 inch hexagon socket head wrench.
7. Slide the pump manifold (2) and piston (3) forward until the piston is out of the T-slot on the slider assembly (4). The heated hose should remain attached.
8. Push piston (3) downward out of the pump manifold (2).
9. Unscrew retainer nut (5) from the pump manifold (2) and remove piston guide (6).
10. Remove upper packing (7) and lower packing (8) from the pump manifold (2).

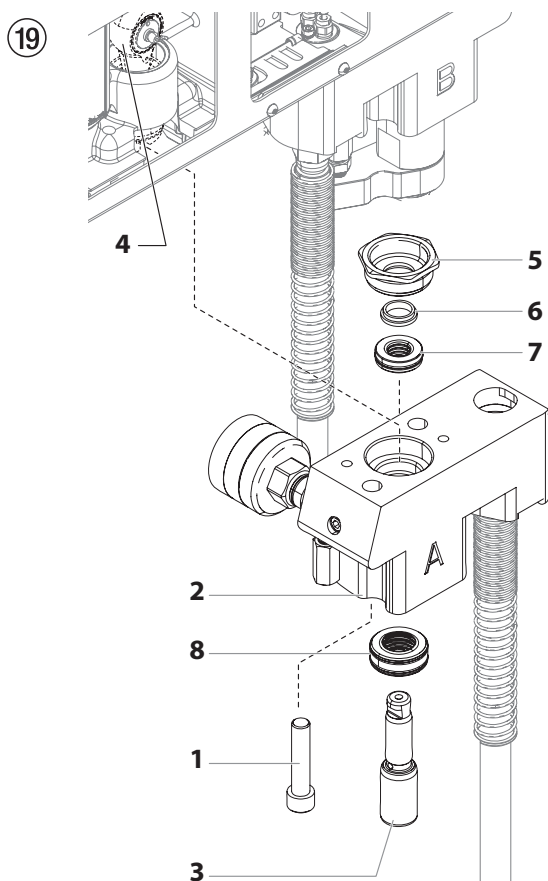

11. Clean pump manifold (2).
12. Lubricate upper packing (7) and lower packing (8) with machine grease.
13. Insert upper packing (Fig. 20) with O-ring (1) and protruding lip (2) downward.

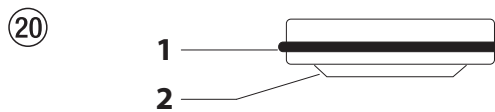

14. Insert lower packing (Fig. 21) with the beveled edge (1) facing upward.

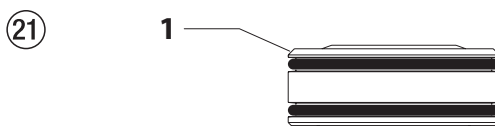

15. Insert piston guide (Fig. 19, Item 6) into the retainer nut (5). Screw retainer nut (5) into the pump manifold (2) and tighten by hand.
16. Push installation tool (included with the replacement packings) for the piston (3) from above onto the piston.
17. Lubricate installation tool and piston (3) with machine grease.
18. Guide piston (3) through the lower packings (8) into the pump manifold (2) from below. Using a rubber mallet, lightly tap the piston (3) from below until it can be seen above the pump manifold.
19. Remove installation tool from piston (3).
20. Carefully tighten retainer nut (5) with adjusting wrench.
21. Re-insert the heated hose wire into the relay on the front of the main unit. Secure the wire by tightening the relay screw.
22. Slide the top of the piston (3) into the T-slot on the slider assembly (4).
23. Position the pump manifold (2) underneath the gear unit housing and push up until it rests against the gear unit housing.
24. Attach pump manifold (2) to the gear unit housing.
25. Screw pump manifold (2) tightly to gear unit housing.
26. Replace the front cover and secure with the front cover screws.
27. Lubricate O-ring (Fig. 17, Item 9) between pump manifold (2) and inlet valve housing with machine grease. Screw inlet valve housing to the pump manifold.
28. Replace the valve swivel assembly onto the inlet valve and secure with the snap ring.

9.7 ELECTRICAL SCHEMATIC

Wiring	
1	Black
2	Red
3	Orange
4	White / blue
5	Blue
6	Brown
7	Green
8	Hose switch </td
9	Pump switch
10	White

Notes (refer to next page)	
a	To pump A
b	To pump B
c	To pressure sensor motor control
d	To contact (0522532)
e	To surge suppressor (704-597)
f	To hose heater
g	To 2A breaker (0522068)
h	To hose assembly (0138726)
i	Hose head short wire

i Make sure to check for grounding continuity after service is performed on any electrical components. Use an ohmmeter to determine that there is continuity between accessible dead-metal parts of the product and the grounding blade of the attachment plug.

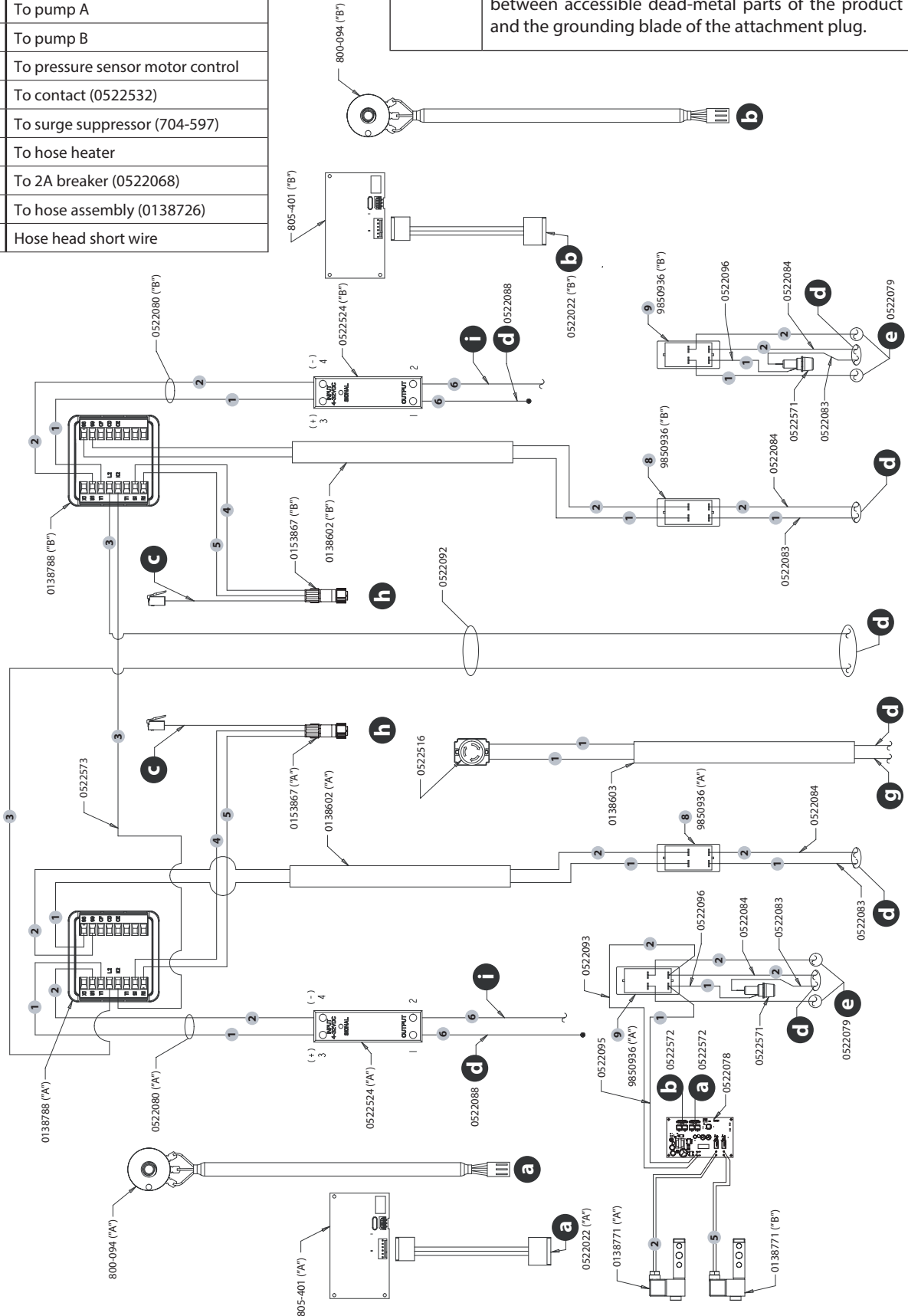

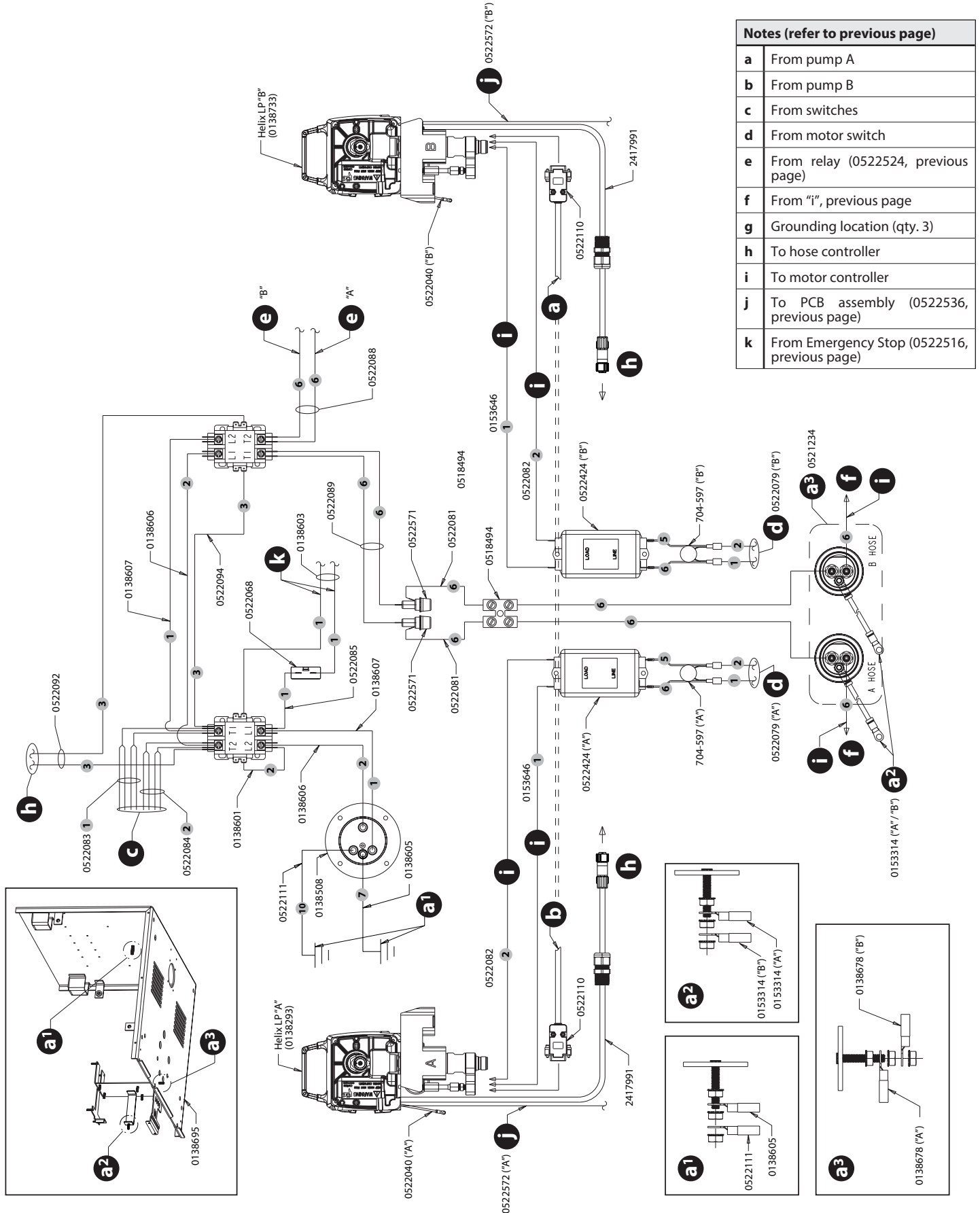

MAIN ASSEMBLY I

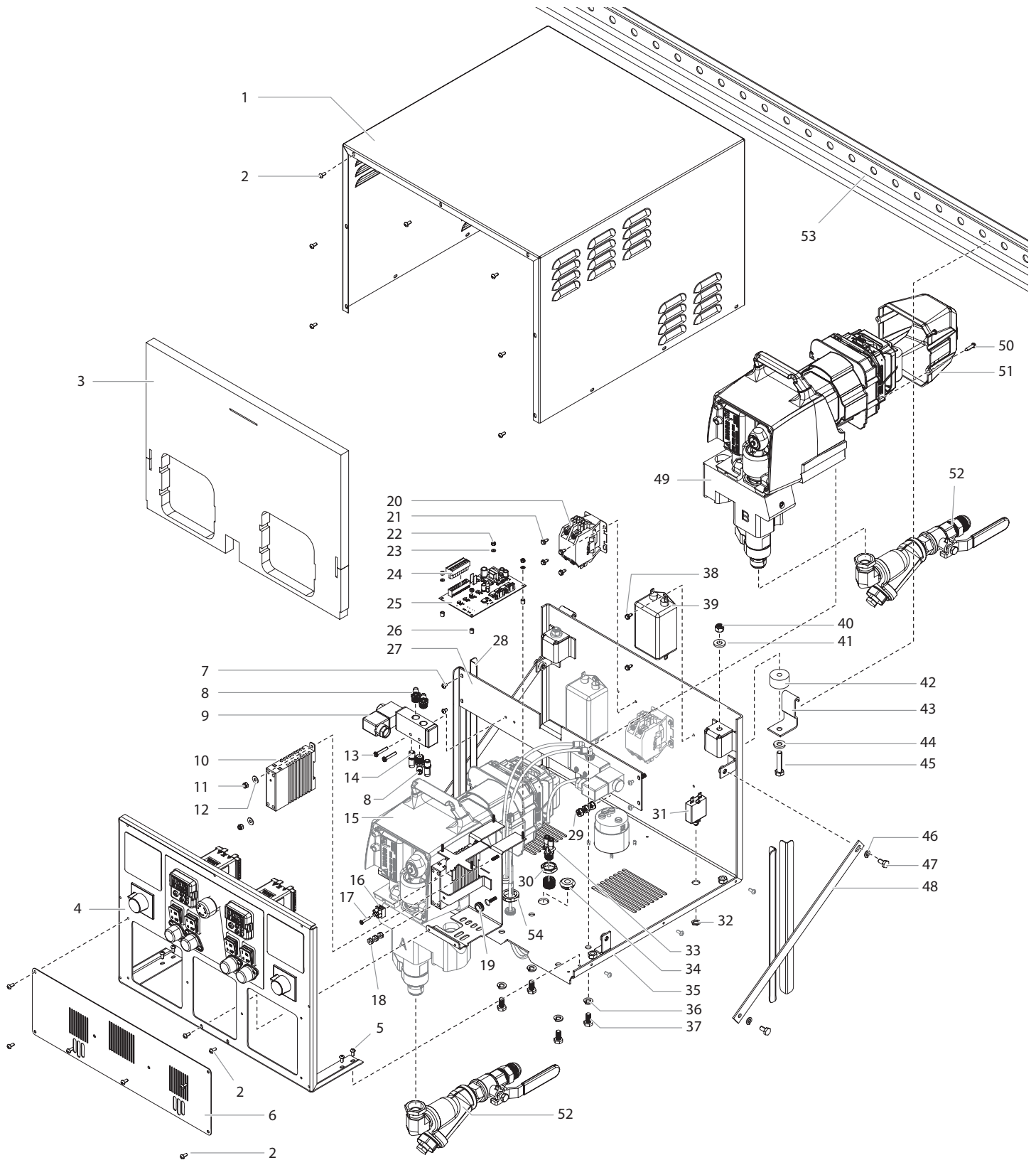

Pos.	Helix LP	Description
1	0138661A	Top shroud
2	700-139	Screw (19)
3	0138676A	Isolation foam
4*	0138698	Display assembly
5	730-260	Screw (4)
6	0138663A	Front panel
7	9805353	Screw (4)
8	0138777	90° swivel (6)
9	0138771	Solenoid valve (2)
10	0522524	Relay, 20 A (2)
11	855-914	Lock nut (4)
12	9822631	Flat washer (4)
13	9805274	Screw (4)
14	0138781	Muffler (4)
15*	0138293	Component pump "A", standard LP unit
	0138031	Component pump "A", drum unit
16	9850577	Terminal block
17	0551495	Screw
18	0524353	Nut (3)
19	800-077	Grommit
20	0522532	Contact, 40A (2)
21	9800340	Screw (8)
22	9805475	Nut (4)
23	9822644	Washer (4)
24	0522579	Terminal block plug
25	0522078A	PCB pressure relief
26	0138502	Spacer (4)
27	0138757A	Solenoid mount
28	0138699A	Bracket, left
29	9812335	Nut (3)
30	-----	Nut
31	0522068	Circuit breaker, 2 A (includes item 31)
32	-----	Nut

Pos.	Helix LP	Description
33	0138776	Swivel fitting
34	0138765	Grommet (2)
35	0138695A	Enclosure weldment
36	860-002	Lock washer (8)
37	9805438	Hex screw (8)
38	9800340	Screw (4)
39	0522424	EMI filter (2)
40	9811122	Nut (2)
41	9822640	Washer (2)
42	0290683	Vibration pad (4)
43	0138669	Vibration mount (2)
44	9822640	Washer (2)
45	860-552	Hex screw (2)
46	9821503	Lock washer (4)
47	0295695	Hex screw (2)
48	0138704A	Bracket, right
49*	0138733	Component pump "B", standard LP unit
	0138032	Component pump "B", drum unit
50	9802266	Screw (4)
51	0138938	Motor cover (2)
52	0138285A	Fluid inlet valve assembly
53	0153647	Hanging bracket
54	0138534	Strain relief nut (2)
	0153866	Relay kit (includes items 10-12)
	0153859	Solenoid kit (includes items 8-9 and 13-14)
	0153860	PCB pressure relief kit (includes items 22-23 and 25)

* See separate listing



When ordering any part number, you will receive a quantity of 1 of that part. If multiples of any part need to be ordered, please specify when ordering.

MAIN ASSEMBLY II

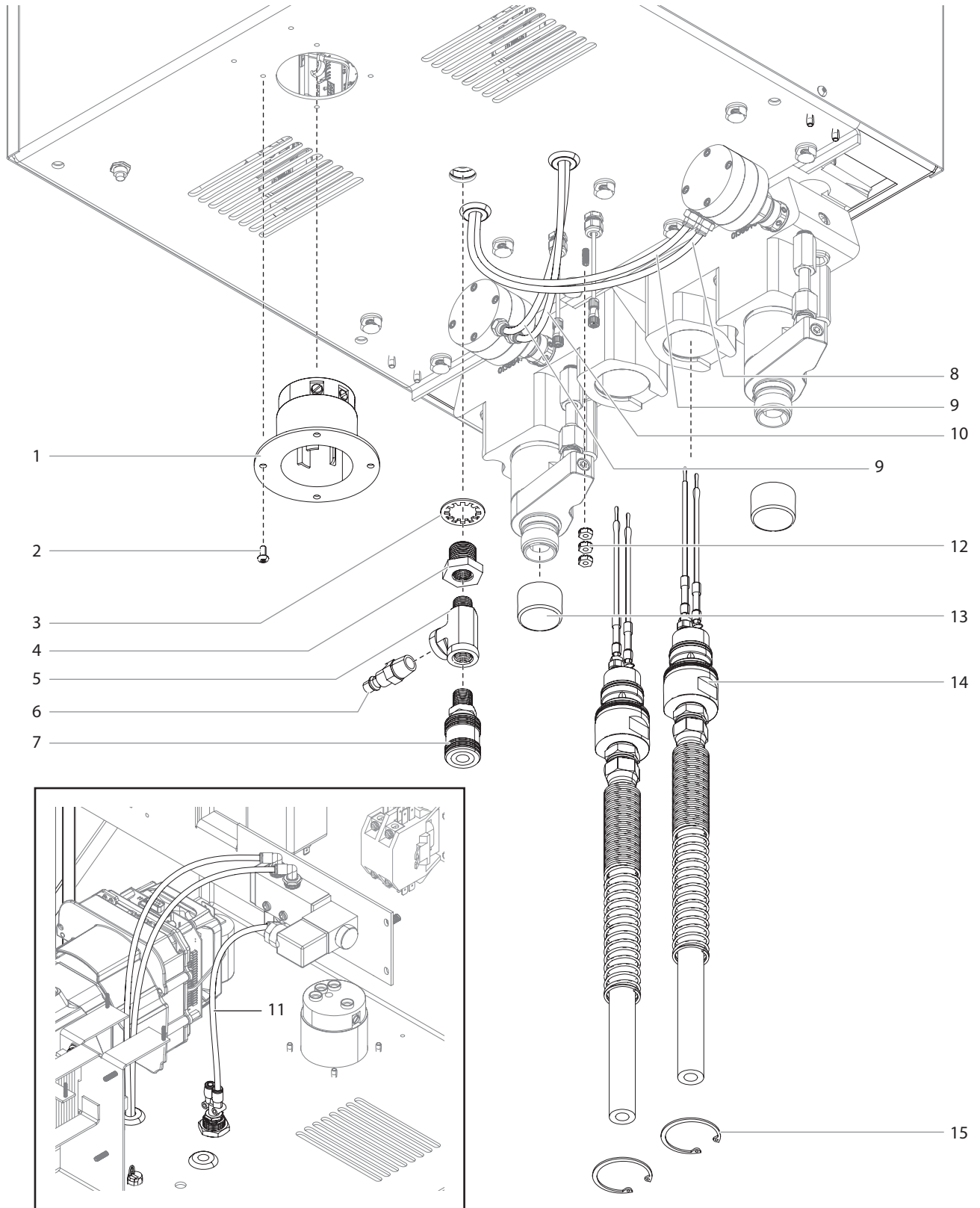

Pos.	Helix LP	Description
1	0138508	Receptacle, 20A
2	9805287	Screw (4)
3	-----	Washer
4	0138772	Fitting (includes item 3 and item 30 in Main Assembly I, page 37).
5	0138774	Tee fitting
6	0275696	Air fitting
7	0138775	Coupling
8	9800090A	Tubing, red
9	9800089A	Tubing, clear (2)
10	9800091A	Tubing, blue
11	9800089B	Tubing, clear (2)
12	0524353	Nut (3)
13	0533905	Cap (2)
14*	0521234	Heated hose assembly (200')
	0521236	Heated hose assembly (100')
15	9822559	Retaining ring (2)

* See separate manual

COMPONENT PUMP ASSEMBLY

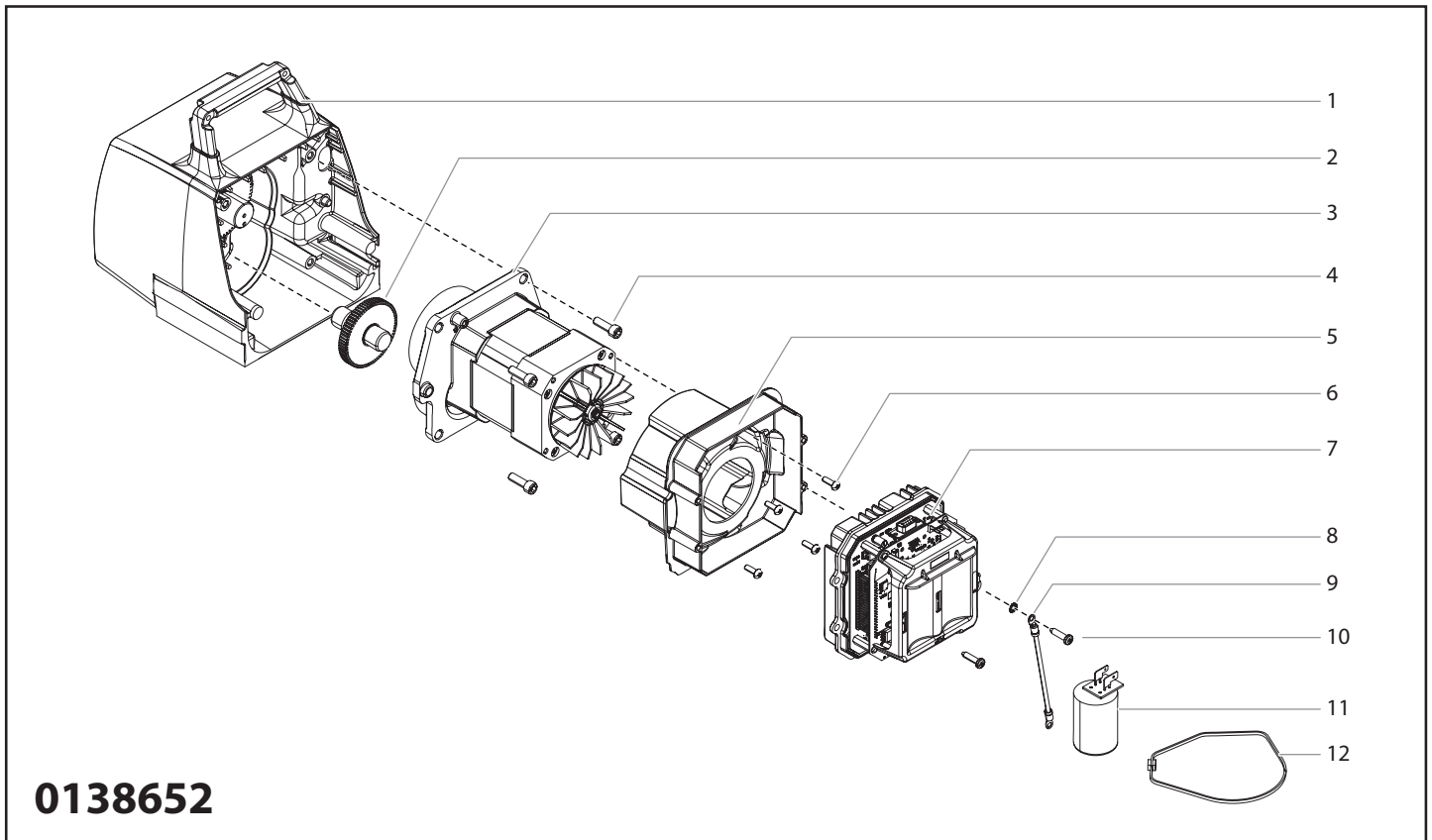
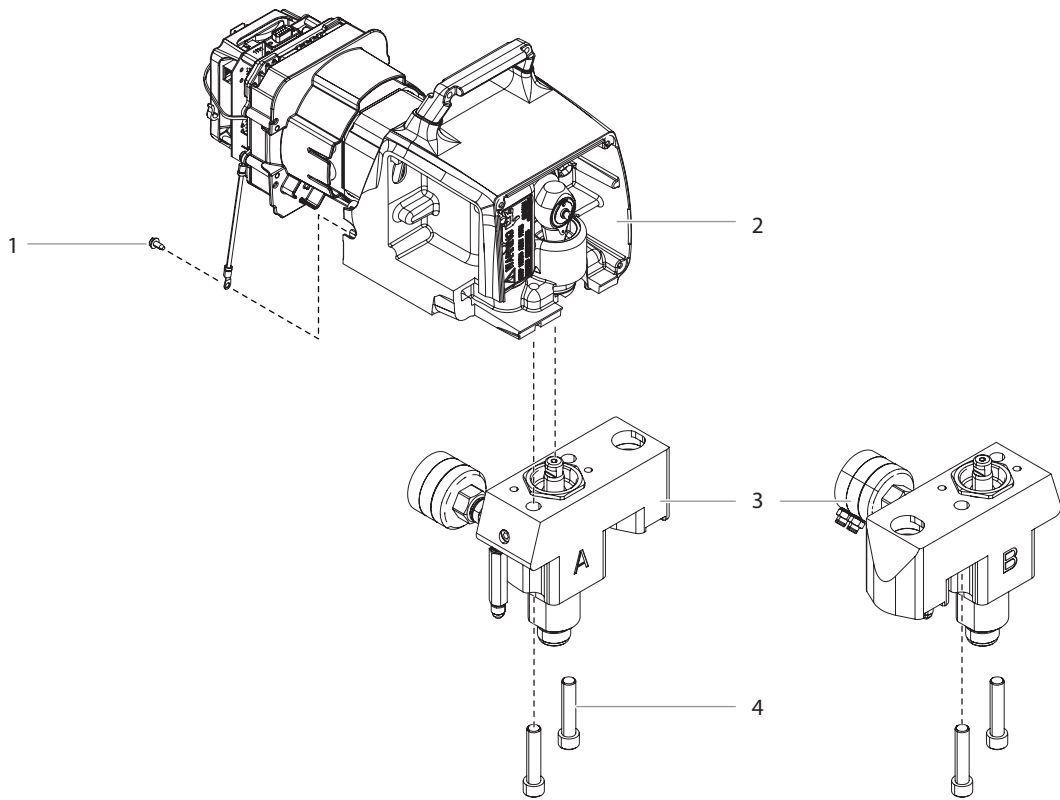

0138652

Pos.	Helix LP A	Helix LP B	Description
1	9800340	9800340	Ground screw
2*	0138652	0138652	Drive assembly
3*	0138031A	0138032A	Fluid section assembly
4	704-117	704-117	Screw (2)
0138652 (Drive Assembly)			
1	0138297A	0138297A	Main housing
2	704-176	704-176	2nd stage gear
3	0138738A	0138738A	Motor assembly
4	700-681	700-681	Screw (4)
5	805-474	805-474	Baffle
6	700-139	700-139	Screw (4)
7	0138975	0138978	Motor controller (see below for schematic)
8	9822106	9822106	Lock washer
9	0522040	0522040	Ground wire
10	9802266	9802266	Screw (2)
11	0522036	0522036	Capacitor assembly
12	770-099	770-099	Tie wrap

* See separate listing

MOTOR CONTROLLER SCHEMATIC

Wiring	
1	Black
2	Red
3	White

Components	
a	Motor (0138738)
b	Capacitor assembly (0522036)
c	Motor controller (0138975 "A", 0138978 "B")
d	Pressure release
e	Hall sensor
f	Potentiometer
g	Display
h	Crank position
i	Pressure sensor

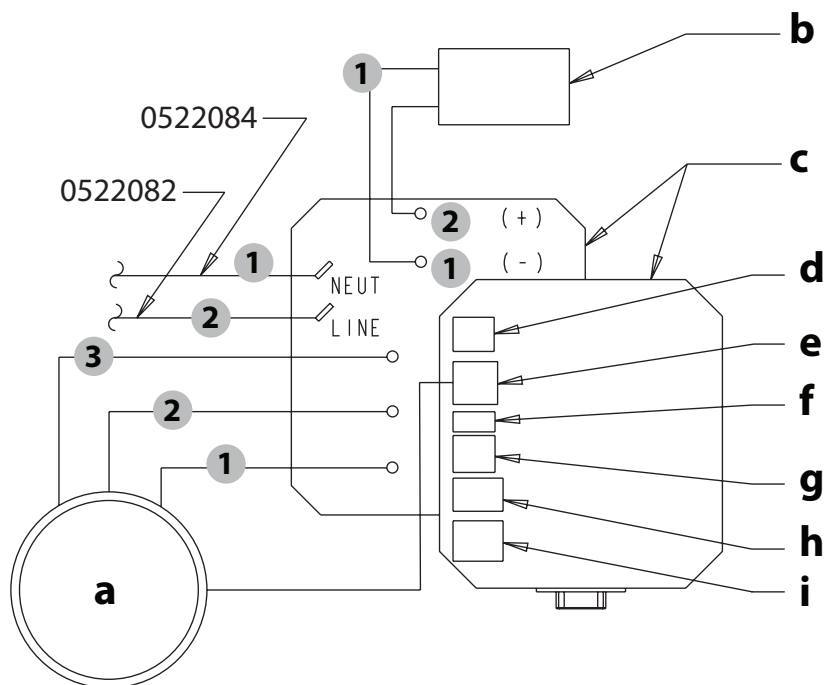

DISPLAY ASSEMBLY

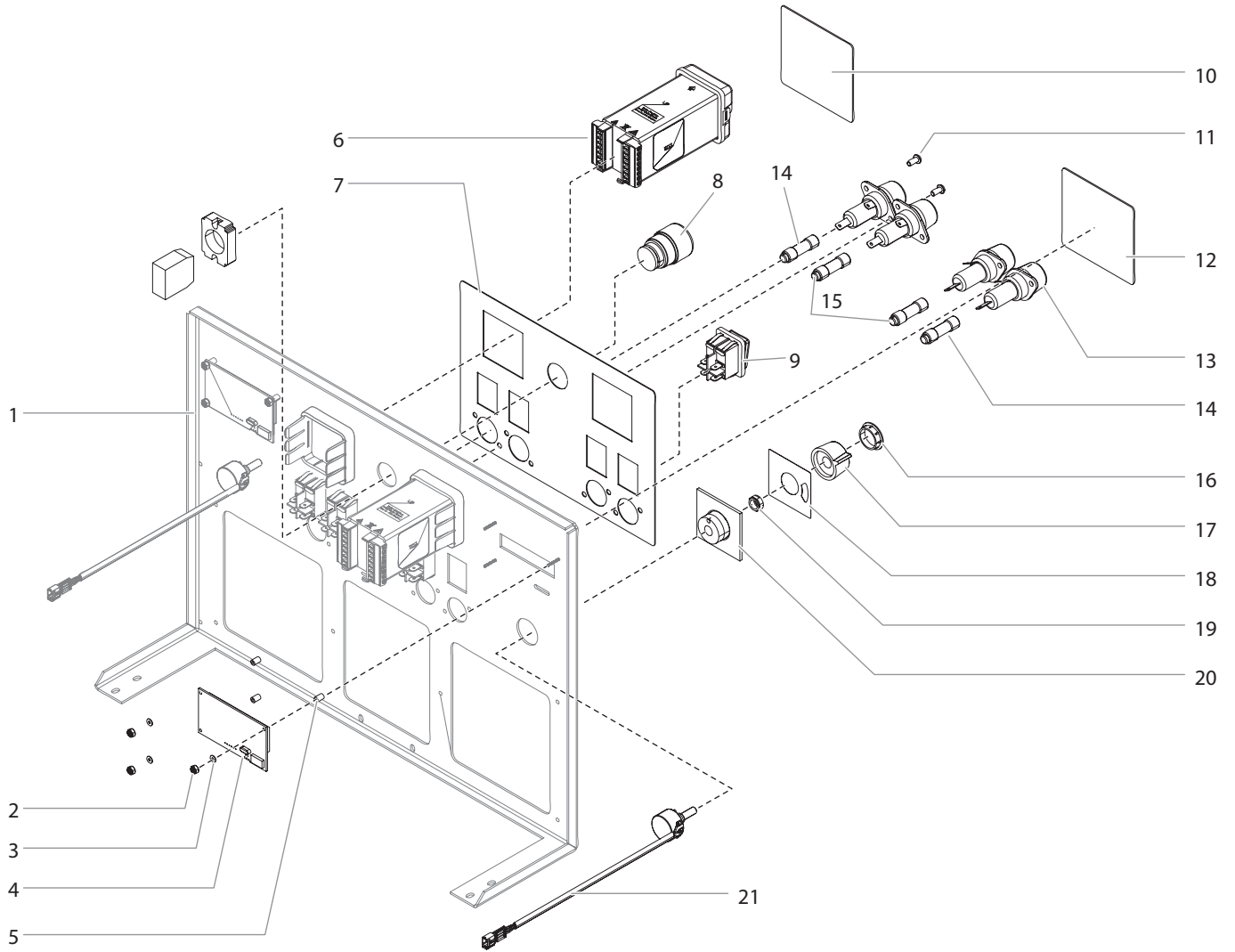

Pos.	Helix LP	Description
1	0138716A	Front panel
2	9812334	Nut (6)
3	9822646	Lock washer (6)
4	805-401	Display (2)
5	0138527	Spacer (6)
6	0138788	Controller (2)
7	0138882A	Display label
8	0522516	Emergency stop button
9	9850936	Switch (4)
10	0138891A	Label, B-side
11	730-260	Screw (8)
12	0138887A	Label, A-side
13	0522571	Fuse holder (4)
14	9851600	Fuse, 8A (2)
15	9851629	Fuse, 12A (2)
16	700-175	Cap (2)
17	700-159	Control knob (2)
18	0138863	Pressure control label (2)
19	700-176	Nut with seal (2)
20	704-293	Mounting plate (2)
21	800-094	Potentiometer assembly (2)
	0153861	Display kit (includes items 2-5)

BRACKET KIT

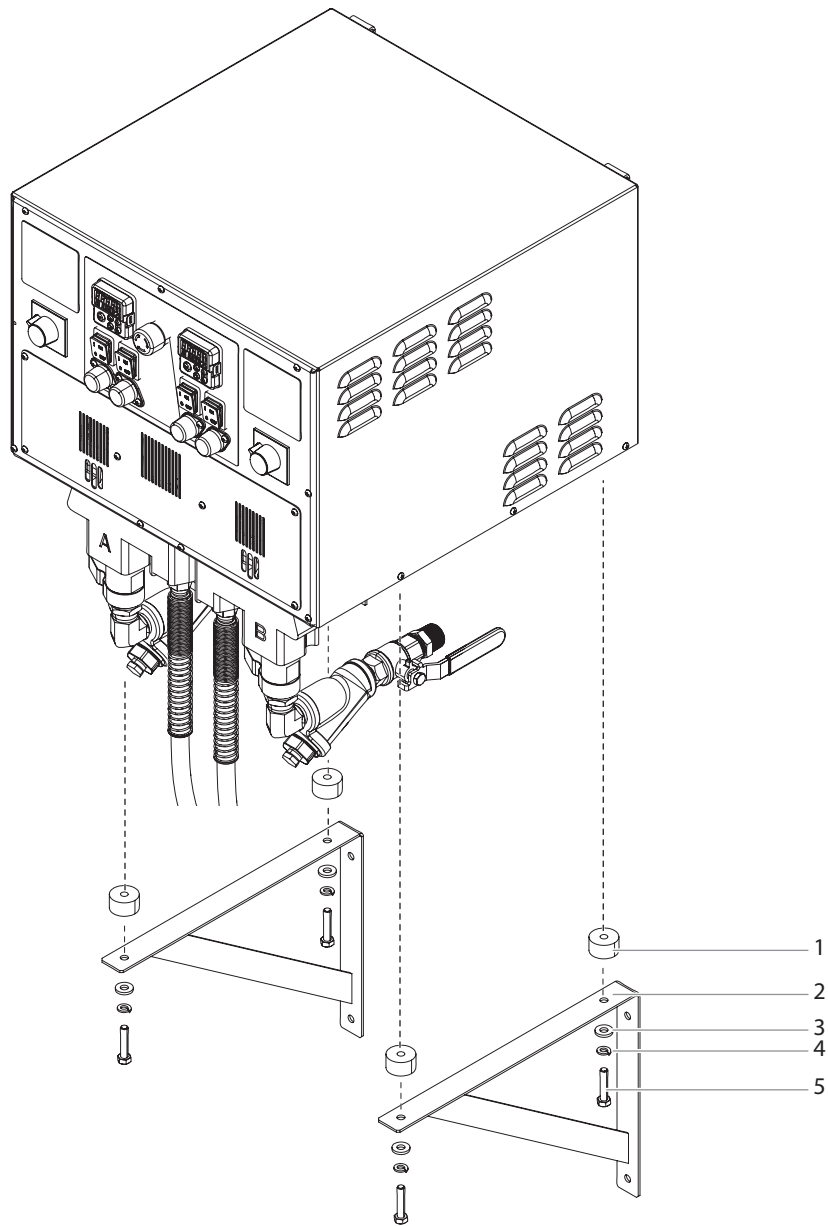

Pos.	Helix LP	Description
1	0290683	Vibration pad (4)
2	0138992	Mounting bracket (2)
3	9822640	Washer (4)
4	860-002	Lock washer (4)
5	860-552	Hex screw
	0138033	Mounting bracket kit (includes items 1-5)

FLUID SECTION (DRUM LP UNITS)

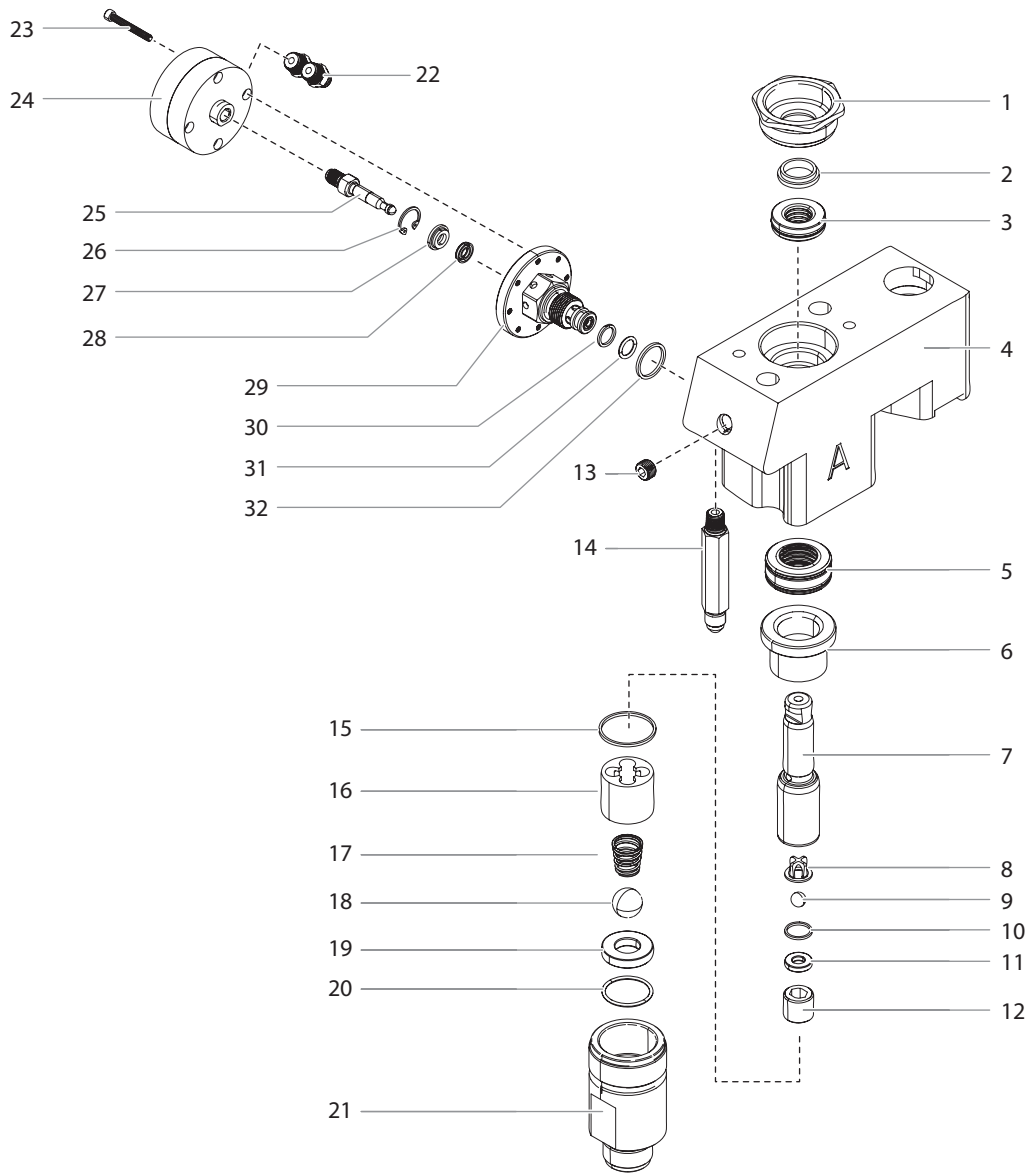

Pos.	Helix LP A 0138031	Helix LP B 0138032	Description
1	730-508	730-508	Retainer
2	700-587	700-587	Upper guide
3	-----	-----	Upper packing
4	0138646A	0138647A	Pump block
5	-----	-----	Lower packing
6	0509590	0509590	Bushing
7	704-551A	704-551A	Piston rod
8	704-610	704-610	Upper ball guide
9	50164	50164	Outlet valve ball
10	704-612	704-612	Crush washer
11	704-558	704-558	Outlet valve seat
12	13481	13481	Outlet valve retainer
13	9885625	9885625	Plug, pipe
14	0153641	0153641	Hex nipple
15	700-821	700-821	Inlet valve seal
16	0138400	0138400	Lower ball guide
17	0138404	0138404	Spring
18	762-145	762-145	Inlet valve ball
19	762-137	762-137	Inlet valve seat
20	762-058	762-058	O-ring, PTFE
21	0138999A	0138999A	Inlet valve housing

Pos.	Helix LP A 0138031	Helix LP B 0138032	Description
22	9885662	9885662	Tube fitting
23	9805468	9805468	Screw (4)
24	0138767	0138767	Air cylinder
25	2407876	2407876	Stem assembly
26	2407878	2407878	Retaining ring
27	2433633	2433633	Bushing
28	2433632	2433632	Seal
29	2407872A	2407872A	Valve body assembly
30	222-012	222-012	Backup ring
31	221-012	221-012	O-ring
32	700-537	700-537	Bypass valve gasket
	704-552A	704-552A	Piston assembly (includes items 7-12)
	704-586	704-586	Fluid section service kit (includes items 2-3, 5, 8-10, 15, 18, and 20).
	0153864	0153864	Air cylinder kit (includes items 22-28)
	0153865	0153865	Guide/valve assembly kit (includes items 29-32)

WARRANTY

Titan Tool, Inc., (“Titan”) warrants that at the time of delivery to the original purchaser for use (“End User”), the equipment covered by this warranty is free from defects in material and workmanship.

SYSTEM WARRANTY:

Two Year (24 months) Manufacturer’s Defects:

With the exception of any special, limited, or extended warranty published by Titan, Titan’s obligation under this warranty is limited to replacing or repairing without charge those parts which, to Titan’s reasonable satisfaction, are shown to be defective within twenty-four (24) months after sale to the End User. This warranty applies only when the unit is installed and operated in accordance with the recommendations and instructions of Titan.

This warranty does not apply in the case of damage or wear caused by abrasion, corrosion or misuse, negligence, accident, faulty installation, substitution of non-Titan component parts, or tampering with the unit in a manner to impair normal operation. This warranty excludes normal wear items and consumables such as, filters, piston, packings, tips, etc.

HELIX MOTOR WARRANTY:

Four Year (48 months) Manufacturer’s Defects:

With the exception of any special, limited, or extended warranty published by Titan, Titan’s obligation under this warranty is limited to replacing or repairing without charge the Helix Motors, to Titan’s reasonable satisfaction, are shown to be defective within forty-eight (48) months after sale to the End User. This warranty applies only when the unit is installed and operated in accordance with the recommendations and instructions of Titan.

This warranty does not apply in the case of damage or wear caused by abrasion, corrosion or misuse, negligence, accident, faulty installation, substitution of non-Titan component parts, or tampering with the unit in a manner to impair normal operation.

Defective parts are to be returned to an authorized Titan sales/service outlet. All transportation charges, including return to the factory, if necessary, are to be borne and prepaid by the End User. Repaired or replaced equipment will be returned to the End User transportation prepaid.

THERE IS NO OTHER EXPRESS WARRANTY. TITAN HEREBY DISCLAIMS ANY AND ALL IMPLIED WARRANTIES INCLUDING, BUT NOT LIMITED TO, THOSE OF MERCHANTABILITY AND FITNESS FOR A PARTICULAR PURPOSE, TO THE EXTENT PERMITTED BY LAW. THE DURATION OF ANY IMPLIED WARRANTIES WHICH CANNOT BE DISCLAIMED IS LIMITED TO THE TIME PERIOD SPECIFIED IN THE EXPRESS WARRANTY. IN NO CASE SHALL TITAN LIABILITY EXCEED THE AMOUNT OF THE PURCHASE PRICE. LIABILITY FOR CONSEQUENTIAL, INCIDENTAL OR SPECIAL DAMAGES UNDER ANY AND ALL WARRANTIES IS EXCLUDED TO THE EXTENT PERMITTED BY LAW.

TITAN MAKES NO WARRANTY AND DISCLAIMS ALL IMPLIED WARRANTIES OF MERCHANTABILITY AND FITNESS FOR A PARTICULAR PURPOSE WITH RESPECT TO ACCESSORIES, EQUIPMENT, MATERIALS OR COMPONENTS SOLD BUT NOT MANUFACTURED BY TITAN. THOSE ITEMS SOLD, BUT NOT MANUFACTURED BY TITAN (SUCH AS GAS ENGINES, SWITCHES, HOSES, ETC.) ARE SUBJECT TO THE WARRANTY, IF ANY, OF THEIR MANUFACTURER. TITAN WILL PROVIDE THE PURCHASER WITH REASONABLE ASSISTANCE IN MAKING ANY CLAIM FOR BREACH OF THESE WARRANTIES.

Note on disposal:

In observance of the European Directive 2002/96/EC on waste electrical and electronic equipment and implementation in accordance with national law, this product is not to be disposed of together with household waste material but must be recycled in an environmentally friendly way!



Titan or one of our dealers will take back your used Titan waste electrical or electronic equipment and will dispose of it for you in an environmentally friendly way. Please ask your local Titan service centre or dealer for details or contact us direct.



The logo for HELIX, featuring the word 'HELIX' in a bold, sans-serif font with a trademark symbol (™) to its upper right. The logo is positioned to the right of a vertical line that descends from the TITAN logo, and a horizontal line crosses this vertical line at the level of the HELIX logo.

UNITED STATES SALES & SERVICE

WEB: www.titantool.com

PHONE: 1-844-458-1215

1770 Fernbrook Lane

Minneapolis, MN 55447

INTERNATIONAL

WEB: www.titantool-international.com